



PMS161

5-ch Touch Keys OTP Controller

Datasheet

Version 0.08 – June 25, 2026

Copyright © 2026 by PADAUK Technology Co., Ltd., all rights reserved

6F-6, No.1, Sec. 3, Gongdao 5th Rd., Hsinchu City 30069, Taiwan, R.O.C.

TEL: 886-3-572-8688  www.padauk.com.tw

IMPORTANT NOTICE

PADAUK Technology reserves the right to make changes to its products or to terminate production of its products at any time without notice. Customers are strongly recommended to contact PADAUK Technology for the latest information and verify whether the information is correct and complete before placing orders.

PADAUK Technology products are not warranted to be suitable for use in life-support applications or other critical applications. PADAUK Technology assumes no liability for such applications. Critical applications include, but are not limited to, those which may involve potential risks of death, personal injury, fire or severe property damage.

Any programming software provided by PADAUK Technology to customers is of a service and reference nature and does not have any responsibility for software vulnerabilities. PADAUK Technology assumes no responsibility for any issue caused by a customer's product design. Customers should design and verify their products within the ranges guaranteed by PADAUK Technology. In order to minimize the risks in customers' products, customers should design a product with adequate operating safeguards.

Table of Contents

Revision History	6
Usage Warning	6
1. Features	7
1.1. Special Features	7
1.2. System Features	7
1.3. CPU Features	7
1.4. Ordering/ Package Information	7
2. General Description and Block Diagram	8
3. Pin Definition and Functional Description	9
4. Device Characteristics	12
4.1. DC/AC Characteristics	12
4.2. Absolute Maximum Ratings.....	13
4.3. Typical IHRC Frequency vs. VDD (calibrated to 16MHz)	13
4.4. Typical ILRC Frequency vs. VDD	14
4.5. Typical NILRC Frequency vs. VDD	14
4.6. Typical IHRC Frequency vs. Temperature (calibrated to 16MHz).....	15
4.7. Typical ILRC Frequency vs. Temperature	15
4.8. Typical NILRC Frequency vs. Temperature.....	16
4.9. Typical Operating Current vs. VDD and CLK=IHRC/n.....	16
4.10. Typical Operating Current vs. VDD and CLK=ILRC/n	17
4.11. Typical IO pull high resistance	17
4.12. Typical IO pull low resistance.....	18
4.13. Typical IO driving current (I _{OH}) and sink current (I _{OL})	18
4.14. Typical IO input high/ low threshold voltage (V _{IH} / V _{IL})	19
4.15. Typical power down current (I _{PD}) and power save current (I _{PS}).....	20
5. Functional Description	21
5.1. Program Memory – OTP	21
5.2. Boot Up	22
5.3. Data Memory – SRAM	22
5.4. Oscillator and clock.....	23
5.4.1. Internal High RC oscillator and Internal Low RC oscillator	23
5.4.2. IHRC calibration	23
5.4.3. IHRC Frequency Calibration and System Clock.....	24
5.4.4. System Clock and LVR levels.....	25
5.4.5. System Clock Switching	26

5.5.	Comparator	27
5.5.1.	Internal reference voltage ($V_{\text{internal R}}$)	28
5.5.2.	Using the comparator	30
5.5.3.	Using the comparator and Bandgap 1.20V	31
5.6.	16-bit Timer (Timer16)	32
5.7.	Watchdog Timer	33
5.8.	Interrupt	33
5.9.	Power-Save and Power-Down	36
5.9.1.	Power-Save mode (“stopexe”)	36
5.9.2.	Power-Down mode (“stopsys”)	37
5.9.3.	Wake-up	38
5.10.	IO Pins	38
5.11.	Reset	40
5.11.1.	8-bit Timer (Timer2)	40
5.11.2.	Using the Timer2 to generate periodical waveform	41
5.12.	8-bit Timer (Timer3)	42
5.13.	Touch Function	44
6.	IO Registers	46
6.1.	ACC Status Flag Register (<i>flag</i>), IO address = 0x00	46
6.2.	Stack Pointer Register (<i>sp</i>), IO address = 0x02	46
6.3.	Clock Mode Register (<i>clkmd</i>), IO address = 0x03	46
6.4.	Interrupt Enable Register (<i>inten</i>), IO address = 0x04	47
6.5.	Interrupt Request Register (<i>intrq</i>), IO address = 0x05	47
6.6.	Timer 16 mode Register (<i>t16m</i>), IO address = 0x06	48
6.7.	Interrupt Edge Select Register (<i>integs</i>), IO address = 0x0c	48
6.8.	Port A Digital Input Enable Register (<i>padier</i>), IO address = 0x0d	49
6.9.	Port A Data Registers (<i>pa</i>), IO address = 0x10	49
6.10.	Port A Control Registers (<i>pac</i>), IO address = 0x11	49
6.11.	Port A Pull-High Registers (<i>paph</i>), IO address = 0x12	49
6.12.	Port A Pull-Low Registers (<i>papl</i>), IO address = 0x13	49
6.13.	Miscellaneous Register (<i>misc</i>), IO address = 0x1b	50
6.14.	Comparator Control Register (<i>gpcc</i>), IO address = 0x1a	50
6.15.	Comparator Selection Register (<i>gpcs</i>), IO address = 0x1e	51
6.16.	Timer2 Control Register (<i>tm2c</i>), IO address = 0x1c	51
6.17.	Timer2 Counter Register (<i>tm2ct</i>), IO address = 0x1d	51
6.18.	Timer2 Scalar Register (<i>tm2s</i>), IO address = 0x17	52
6.19.	Timer2 Bound Register (<i>tm2b</i>), IO address = 0x09	52
6.20.	Timer3 Control Register (<i>tm3c</i>), IO address = 0x32	52

6.21.	Timer3 Counter Register (<i>tm3ct</i>), IO address = 0x33.....	52
6.22.	Timer3 Scalar Register (<i>tm3s</i>), IO address = 0x34.....	53
6.23.	Timer3 Bound Register (<i>tm3b</i>), IO address = 0x35.....	53
6.24.	Touch Selection Register (<i>ts</i>), IO address = 0x37.....	53
6.25.	Touch Charge Control Register (<i>tcc</i>), IO address = 0x38.....	54
6.26.	Touch Key Enable 1 Register (<i>tke1</i>), IO address = 0x3b.....	54
6.27.	Touch Key Charge Counter High Register (<i>tkch</i>), IO address = 0x3e.....	54
6.28.	Touch Key Charge Counter Low Register (<i>tkcl</i>), IO address = 0x3f.....	54
6.29.	External Power Operate Register (<i>eoscr</i>), IO address = 0x0a.....	55
6.30.	Touch parameter setting Register (<i>tps</i>), IO address = 0x3C.....	55
6.31.	Touch parameter setting Register (<i>tps2</i>), IO address = 0x3D.....	55
7.	Instructions	56
7.1.	Data Transfer Instructions	57
7.2.	Arithmetic Operation Instructions	59
7.3.	Shift Operation Instructions	61
7.4.	Logic Operation Instructions.....	62
7.5.	Bit Operation Instructions.....	64
7.6.	Conditional Operation Instructions	65
7.7.	System control Instructions	67
7.8.	Summary of Instructions Execution Cycle.....	68
7.9.	Summary of affected flags by Instructions.....	69
7.10.	BIT definition	69
8.	Code Option Table.....	70
9.	Special Notes	70
9.1.	Using IC	70
9.1.1.	IO pin usage and setting.....	70
9.1.2.	Interrupt.....	71
9.1.3.	System clock switching.....	71
9.1.4.	Power down mode, wakeup and watchdog	71
9.1.5.	TIMER time out.....	72
9.1.6.	IHRC.....	72
9.1.7.	LVR	72
9.1.8.	Programming Writing.....	73
9.1.8.1.	Using 5S-P-003 to write PMS161.....	73
9.1.8.2.	Using 5S-P-003B to write PMS161	75
9.2.	Using ICE.....	77

Revision History

Revision	Date	Description
0.06	2024/09/13	1. Updated description of Special Features 2. Updated feature diagrams 4.3 ~ 4.10 and 4.14
0.07	2025/09/10	1. Delete section 7.1 and 7.9 description of unsupported ldtbx instruction 2. Amend the description in Section 5.10.1: Add the sentence "It will be triggered on both the rising and falling edges"
0.08	2026/06/25	1. Add PA7 to PA6 for PMS161-U06A & PMS161-U06B

Usage Warning

User must read all application notes of the IC by detail before using it.

Please visit the official website to download and view the latest APN information associated with it.

<http://www.padauk.com.tw/en/product/show.aspx?num=150&kw=PMS161>

(The following picture are for reference only.)

◆◆ PMS161 ◆◆

◆ Operating temperature : -40°C ~ 85°C

Feature
Documents
Software & Tools
Application Note

Content	Description	Download (CN)	Download (EN)
APN002	Over voltage protection		
APN003	Over voltage protection		
APN004	Semi-Automatic writing handler		
APN007	Setting up LVR level		
APN011	Semi-Automatic writing Handler improve writing stability		
APN015	Capacitive touch screen PCB design guide		
APN018	Double bonding check on writer for specific packages		
APN019	E-PAD PCB layout guideline		

1. Features

1.1. Special Features

- ◆ Operating temperature range: -40°C ~ 85°C

1.2. System Features

- ◆ 1.5KW OTP program memory
- ◆ 96 Bytes data RAM
- ◆ Maximum 5 IO pins can be selected as TOUCH PAD individually
- ◆ One hardware 16-bit timer
- ◆ Two hardware 8-bit timer
- ◆ One hardware comparator
- ◆ 6 IO pins with optional pull-high/pull-low resistor
- ◆ Bandgap circuit to provide 1.2V Bandgap voltage
- ◆ Clock sources: internal high RC oscillator (IHRC) and internal low RC oscillator (ILRC)
- ◆ Sixteen Levels of LVR reset: 4.5V, 4.0V, 3.75V, 3.5V, 3.3V, 3.15V, 3.0V, 2.7V, 2.5V, 2.4V, 2.3V, 2.2V, 2.1V, 2.0V, 1.9V, 1.8V
- ◆ Two selectable external interrupt pin
- ◆ Internal LDO for touch noise immunity
- ◆ One low-power clock (NILRC) wake-up stopsys regularly.

1.3. CPU Features

- ◆ Operating modes: One processing unit mode
- ◆ 88 powerful instructions
- ◆ Most instructions are 1T execution cycle
- ◆ Programmable stack pointer to provide adjustable stack level (Using 2 bytes SRAM for one stack level)
- ◆ Direct and indirect addressing modes for data and instructions
- ◆ All data memories are available for use as an index pointer
- ◆ Separated IO and memory space

1.4. Ordering/ Package Information

- ◆ PMS161-U06A: SOT23-6 (60mil)
- ◆ PMS161-U06B: SOT23-6 (60mil)
- ◆ PMS161-2N06: DFN6 (2*2mm)
- ◆ PMS161-2N08A: DFN8 (2*2mm)
- ◆ PMS161-2N08B: DFN8 (2*2mm)
- ◆ PMS161-S08A: SOP8 (150mil)
- ◆ PMS161-S08B: SOP8 (150mil)
- Please refer to the official website file for package size information : "Package information "

2. General Description and Block Diagram

The PMS161 is a fully static, OTP-based 8bit CMOS MCU; it employs RISC architecture and most the instructions are executed in one cycle except that few instructions are two cycles that handle indirect memory access.

A maximum 5-ch touch keys controller is built inside PMS161. Besides, PMS161 also includes 1.5KW OTP program memory, 96 bytes data SRAM, one hardware 16-bit timer, one hardware 8-bit Timer3 and one hardware 8-bit Timer2.

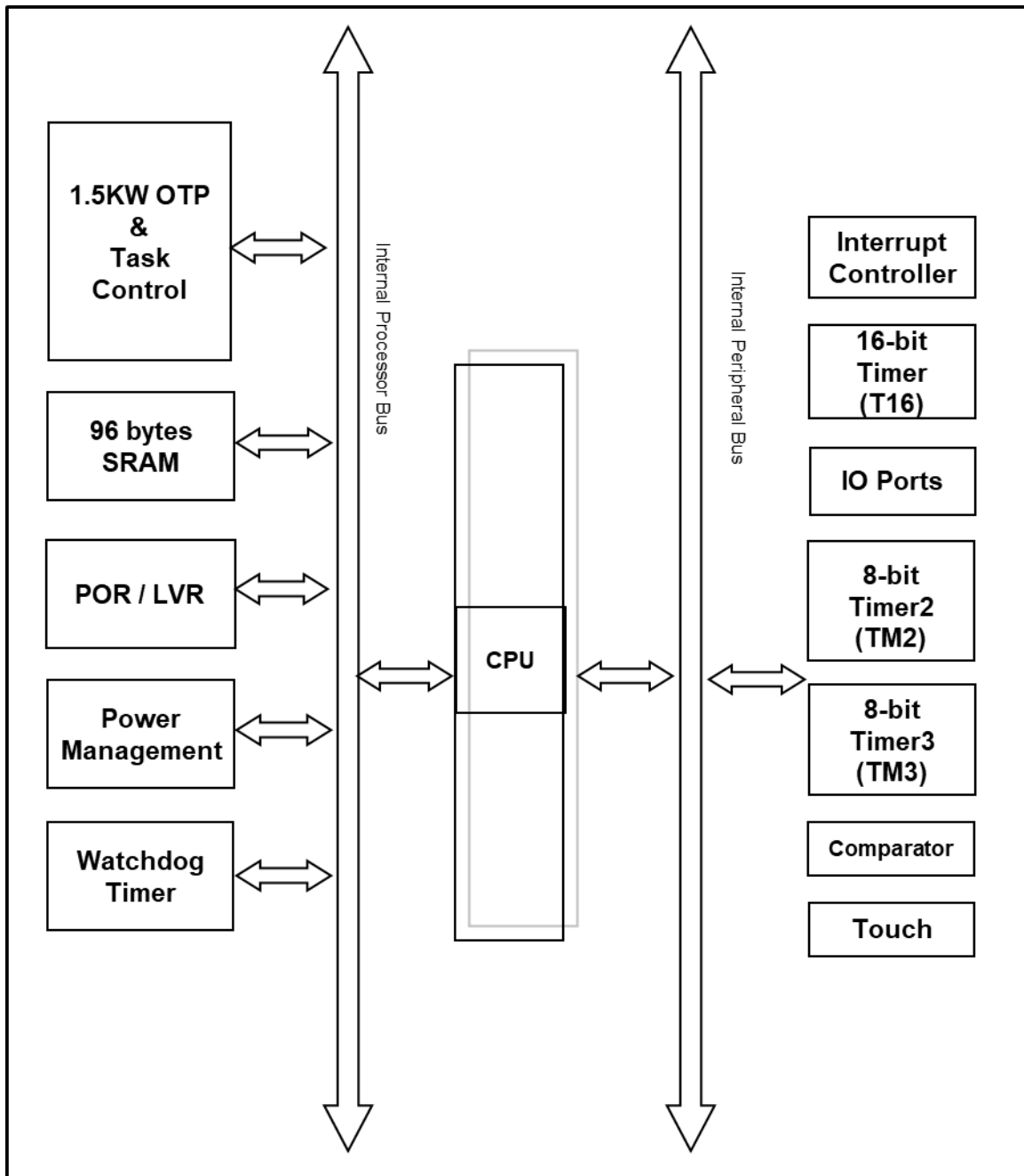
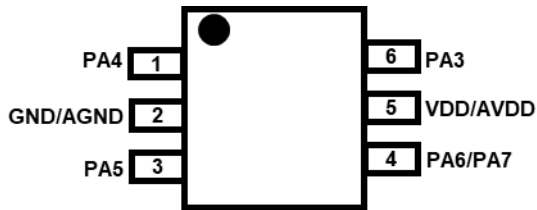
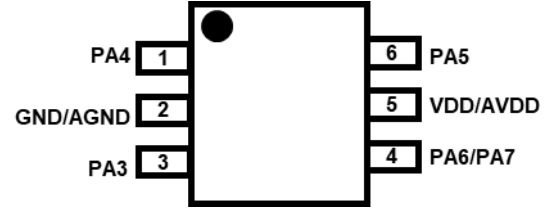

Fig. 1: PMS161 Block Diagram

3. Pin Definition and Functional Description



PMS161-U06A: SOT23-6 (60mil)



PMS161-U06B: SOT23-6 (60mil)

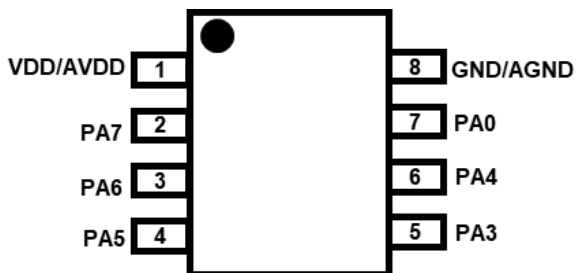

PMS161-S08A: SOP8 (150mil)

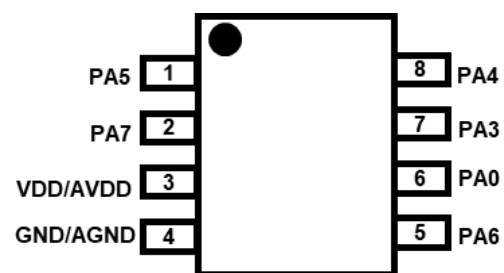

PMS161-S08B: SOP8 (150mil)

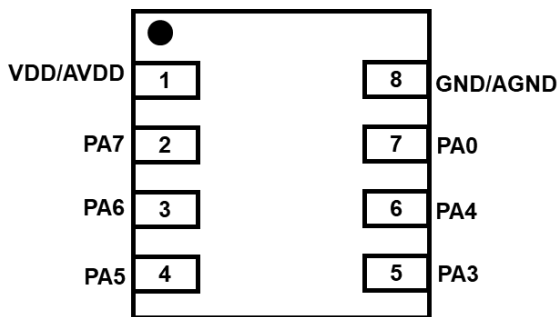

PMS161-2N08A: DFN8 (2*2mm)

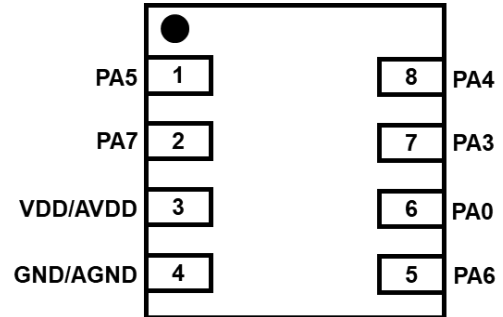

PMS161-2N08B: DFN8 (2*2mm)

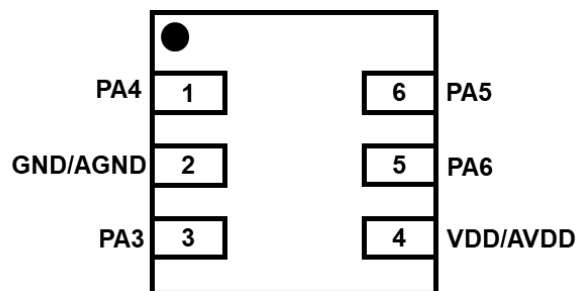

PMS161-2N06: DFN6 (2*2mm)

PMS161

5-ch Touch Keys OTP Controller

Pin Name	Pin & Buffer Type	Description
PA6 / TK1	IO ST / CMOS / Analog	<p>This pin can be used as:</p> <p>(1) Bit 6 of port A. It can be configured as digital input or two-state output, with pull-high resistor independently by software.</p> <p>(2) Touch Key 1</p> <p>When this pin is configured as analog input, please use bit 6 of register padier to disable the digital input to prevent leakage current.</p>
PA5 / TK0 / INT0 / PRSTB / VPP	IO ST / CMOS	<p>This pin can be used as:</p> <p>(1) Bit 5 of port A. It can be configured as digital input or two-state output, with pull-high/pull-low resistor independently by software.</p> <p>(2) Touch Key 0</p> <p>(3) Optional external interrupt line 0. <u>Both rising edge and falling edge are accepted to request interrupt service.</u></p> <p>(4) External reset pin</p> <p>(5) VPP for OTP programming</p>
PA4 / TK3 / CIN-	IO ST / CMOS / Analog	<p>This pin can be used as:</p> <p>(1) Bit 4 of port A. It can be configured as digital input or two-state output, with pull-high/pull-low resistor independently by software.</p> <p>(2) Touch Key 3</p> <p>(3) Minus input source of comparator.</p> <p>When this pin is configured as analog input, please use bit 4 of register padier to disable the digital input to prevent leakage current.</p>
PA3 / TK2 / CIN-	IO ST / CMOS / Analog	<p>This pin can be used as:</p> <p>(1) Bit 3 of port A. It can be configured as digital input or two-state output, with pull-high/pull-low resistor independently by software.</p> <p>(2) Touch Key 2</p> <p>(3) Minus input source of comparator.</p> <p>When this pin is configured as analog input, please use bit 3 of register padier to disable the digital input to prevent leakage current.</p>
PA0 / INT0 / TK4	IO ST / CMOS / Analog	<p>This pin can be used as:</p> <p>(1) Bit 0 of port A. It can be configured as digital input or two-state output, with pull-high/pull-low resistor independently by software.</p> <p>(2) Optional external interrupt line 0. <u>Both rising edge and falling edge are accepted to request interrupt service.</u></p> <p>(3) Touch Key 4</p> <p>When this pin is configured as analog input, please use bit 0 of register padier to disable the digital input to current leakage current.</p>

PMS161

5-ch Touch Keys OTP Controller

Pin Name	Pin & Buffer Type	Description
PA7 / CS	IO ST / CMOS / Analog	This pin can be used as: (1) Bit 7 of port A. It can be configured as digital input or two-state output, with pull-high/pull-low resistor independently by software. (2) External Capacitor When this pin is configured as CS, the input function of this pin is disabled to prevent leakage current regardless of the setting of the bit 7 of register <i>padier</i> .
VDD / AVDD	VDD / AVDD	VDD: Digital positive power AVDD: Analog positive power VDD is the IC power supply while AVDD is the Analog positive power supply. AVDD and VDD are double bonding internally and they have the same external pin.
GND / AGND	GND / AGND	GND: Digital negative power AGND: Analog negative power GND is the IC ground pin while AGND is the Analog negative ground pin. AGND and GND are double bonding internally and they have the same external pin.
Notes: IO: Input/Output; ST: Schmitt Trigger input; Analog: Analog input pin; CMOS: CMOS voltage level		

4. Device Characteristics

4.1. DC/AC Characteristics

All data are acquired under the conditions of $V_{DD}=5V$, $f_{SYS}=2MHz$ unless noted.

Symbol	Description	Min.	Typ	Max.	Unit	Conditions
V_{DD}	Operating Voltage	2.2 [#] 2.0		5.5 5.5	V	#For Touch application Subject to LVR tolerance
LVR%	Low Voltage Reset Tolerance	-5		5	%	
f_{SYS}	System clock (CLK)* = IHRC/2 IHRC/4 IHRC/8 ILRC	0 0 0	40K	8M 4M 2M	Hz	$V_{DD} \geq 3.5V$ $V_{DD} \geq 2.5V$ $V_{DD} \geq 2.2V$ $V_{DD} = 5V$
I_{OP}	Operating Current		0.5 32		mA uA	$f_{SYS} = IHRC/16 = 1MIPS@5.0V$ $f_{SYS} = ILRC = 40KHz@5.0V$
I_{PD}	Power Down Current (by stopsys command)		0.2 0.1 0.6 0.3		uA	$V_{DD} = 5V$ $V_{DD} = 3V$ $V_{DD} = 5V$, NILRC Enable $V_{DD} = 3V$, NILRC Enable
I_{PS}	Power Save Current (by stopexe command) *Disable IHRC		2.1 0.8		uA	$V_{DD} = 5V$ $V_{DD} = 3V$
V_{IL}	Input low voltage for IO lines	0		$0.1 V_{DD}$	V	
V_{IH}	Input high voltage for IO lines	$0.7 V_{DD}$		V_{DD}	V	
I_{OL}	IO lines sink current (Normal)		18		mA	$V_{DD} = 5.0V$, $V_{OL} = 0.5V$
I_{OH}	IO lines drive current (Normal)		13		mA	$V_{DD} = 5.0V$, $V_{OH} = 4.5V$
V_{IN}	Input voltage	-0.3		$V_{DD} + 0.3$	V	
$I_{INJ} (PIN)$	Injected current on pin		1		uA	$V_{DD} + 0.3 \geq V_{IN} \geq -0.3$
R_{PH}	Pull-high Resistance		78		K Ω	$V_{DD} = 5.0V$
R_{PL}	Pull-low Resistance		70		K Ω	$V_{DD} = 5.0V$
f_{IHRC}	Frequency of IHRC after calibration *	15.76*	16*	16.24*	MHz	$25^{\circ}C$, $V_{DD} = 2.2V \sim 5.5V$
		15.20*	16*	16.80*		$V_{DD} = 2.2V \sim 5.5V$, $-40^{\circ}C < T_a < 85^{\circ}C$ *
		14.60*	16*	17.40*		$V_{DD} = 2.0V \sim 5.5V$, $-40^{\circ}C < T_a < 85^{\circ}C$
f_{ILRC}	Frequency of ILRC *		40		KHz	$V_{DD} = 5.0V$
f_{NILRC}	Frequency of NILRC *		12.5		KHz	$V_{DD} = 5.0V$
t_{INT}	Interrupt pulse width	30			ns	$V_{DD} = 5.0V$
t_{WDT}	Watchdog timeout period		8192		ILRC clock perio d	misc[1:0]=00 (default)
			16384			misc[1:0]=01
			65536			misc[1:0]=10
			262144			misc[1:0]=11

Symbol	Description	Min.	Typ	Max.	Unit	Conditions
t _{WUP}	Wake-up time period for fast wake-up		45		T _{ILRC}	Where T _{ILRC} is the time period of ILRC
	Wake-up time period for normal wake-up		3000			
t _{SBP}	System boot-up period from power-on		50		ms	@ V _{DD} =5V
t _{RST}	External reset pulse width	120			us	@ V _{DD} =5V

*These parameters are for design reference, not tested for every chip.

*The characteristic diagrams are the actual measured values. Considering the influence of production drift and other factors, the data in the table are within the safety range of the actual measured values.

4.2. Absolute Maximum Ratings

Parameter	Maximum Rating	Notes
Supply Voltage	2.2V ~ 5.5V	If V _{DD} is over the maximum rating, it may lead to a permanent damage of IC
Input Voltage	-0.3V ~ V _{DD} + 0.3V	
Operating Temperature	-40°C ~ 85°C	
Storage Temperature	-50°C ~ 125°C	
Junction Temperature	150°C	

4.3. Typical IHRC Frequency vs. VDD (calibrated to 16MHz)

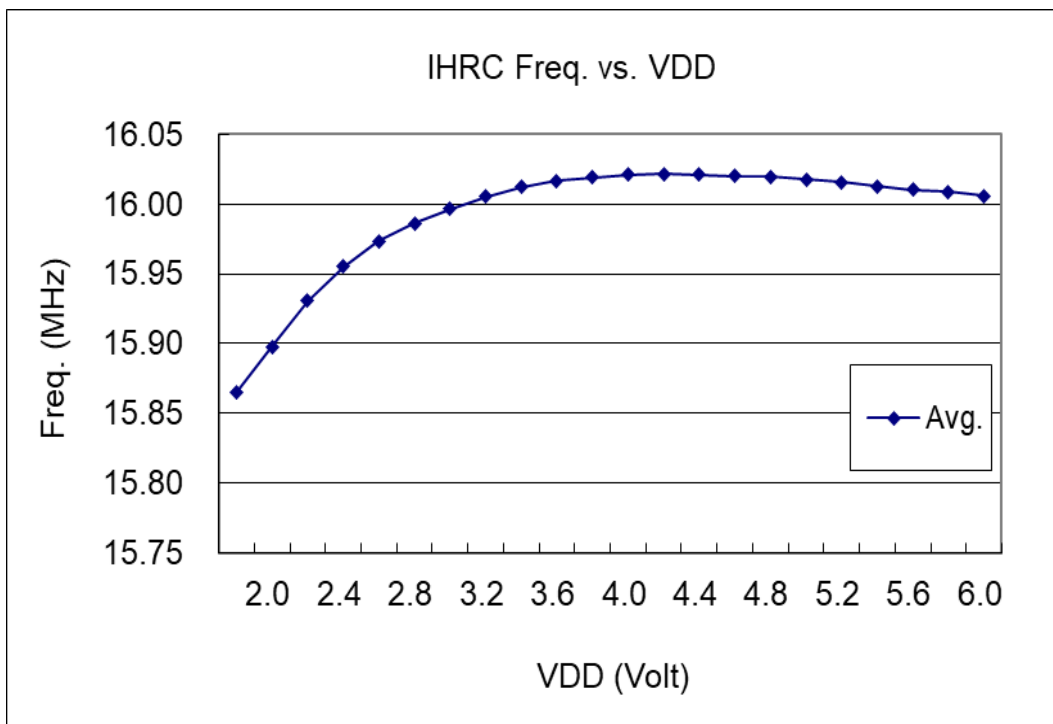

4.4. Typical ILRC Frequency vs. VDD

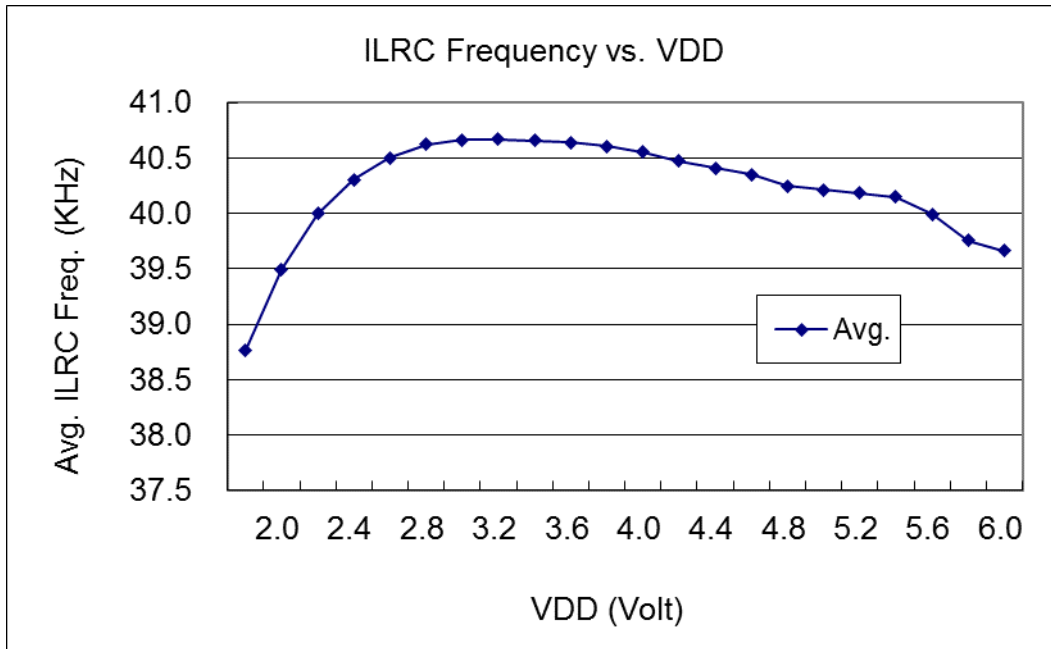

4.5. Typical NILRC Frequency vs. VDD

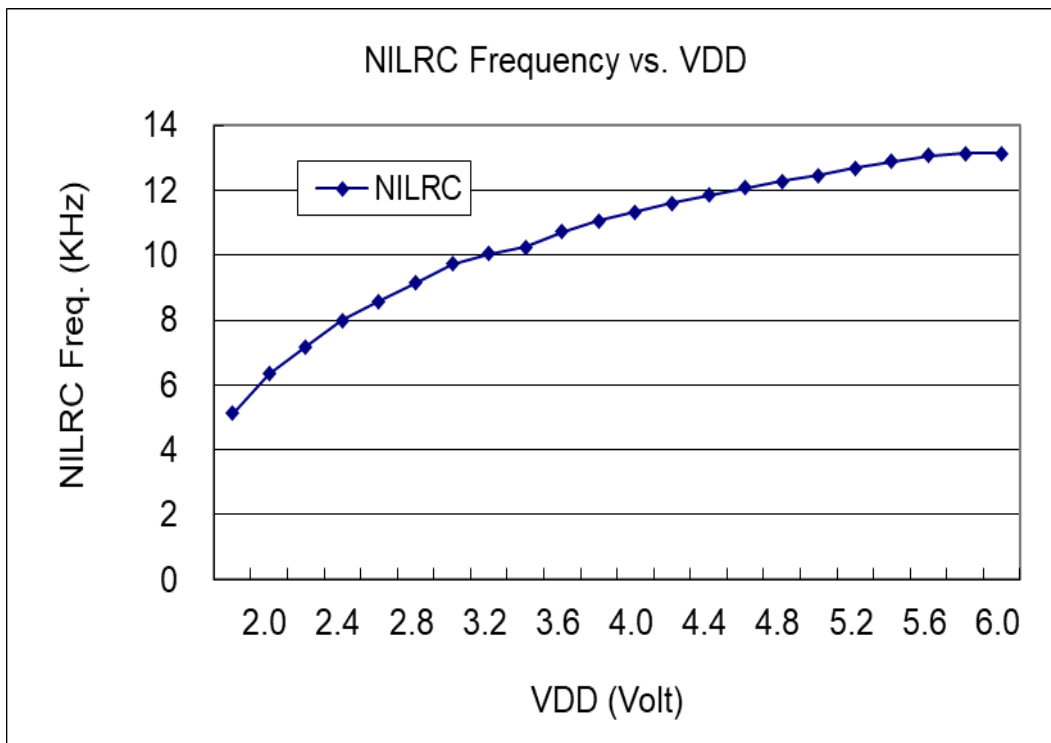

4.6. Typical IHRC Frequency vs. Temperature (calibrated to 16MHz)

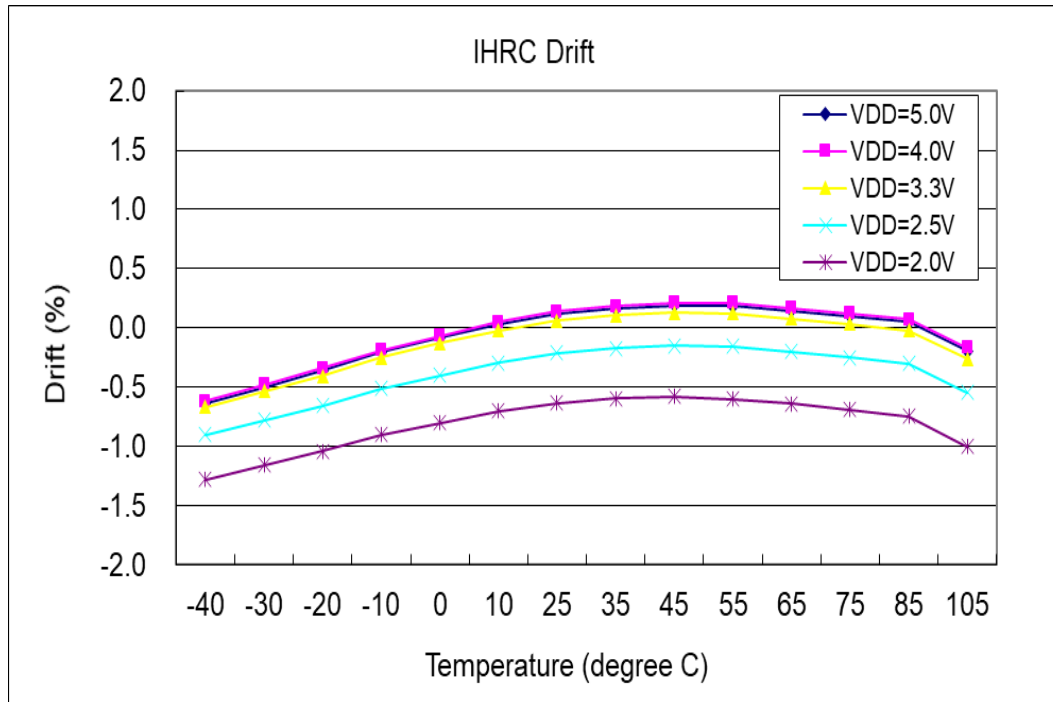

4.7. Typical ILRC Frequency vs. Temperature

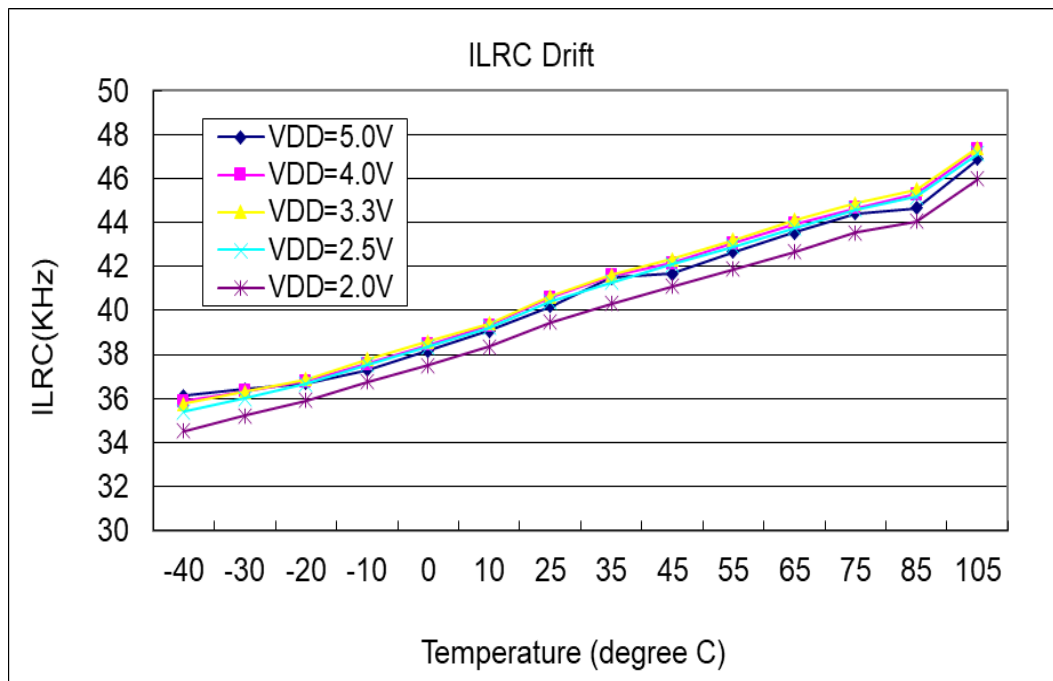

4.8. Typical NILRC Frequency vs. Temperature

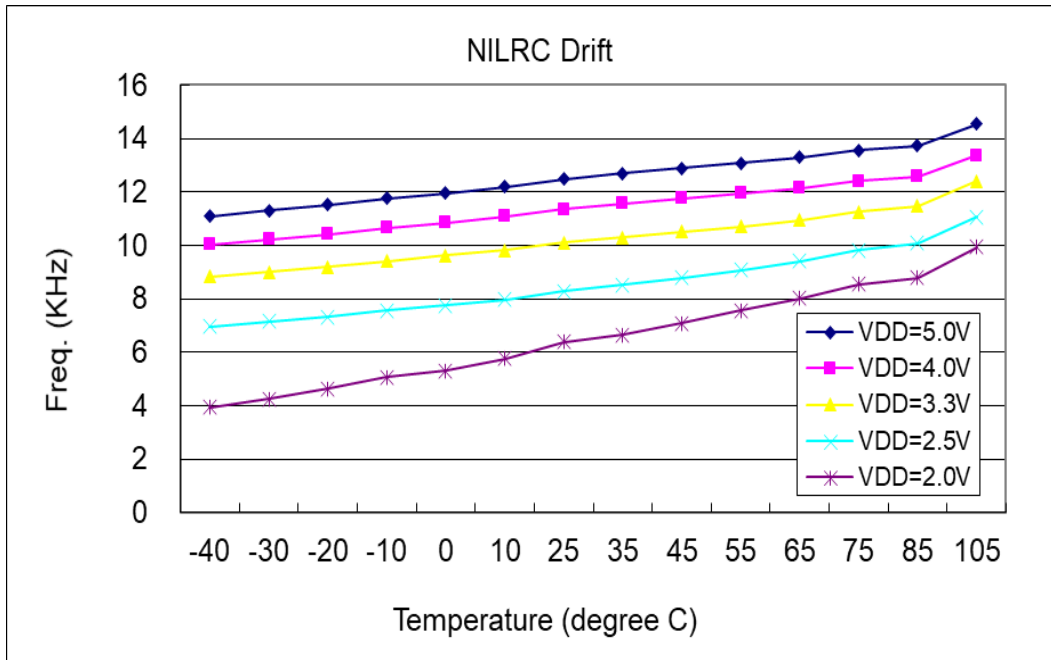

4.9. Typical Operating Current vs. VDD and CLK=IHRC/n

➤ Conditions:

tog pa0(1s), **ON**: Bandgap, LVR, IHRC

no t16m, **no** interrupt, **no** floating IO pins, disable ILRC, **Touch**: Disable

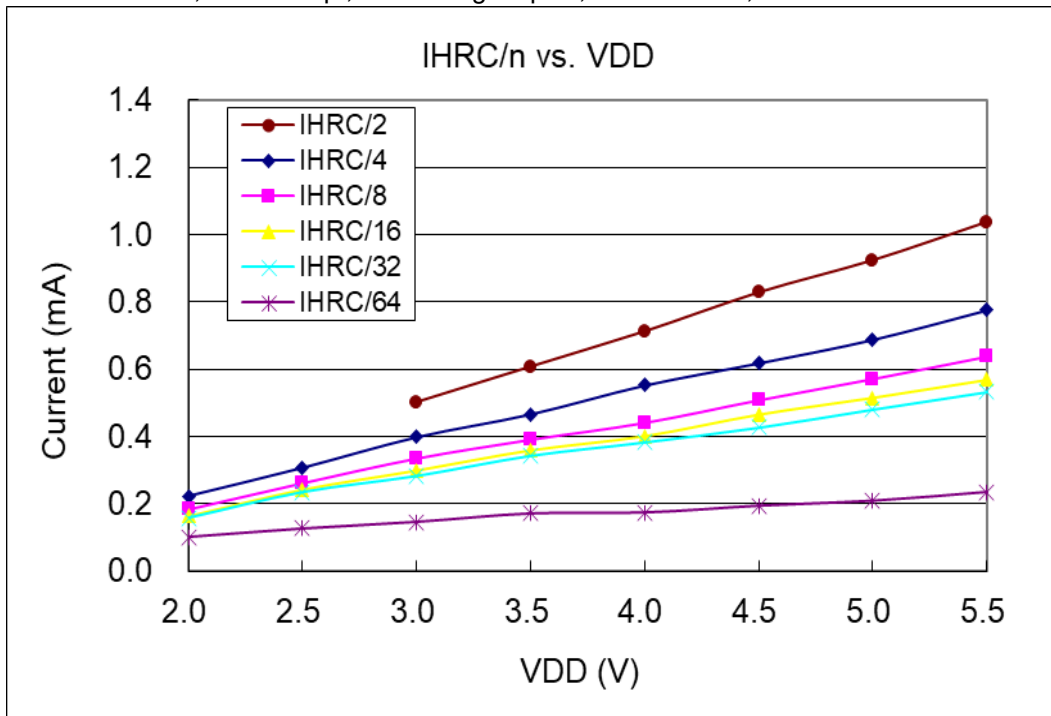

4.10. Typical Operating Current vs. VDD and CLK=ILRC/n

- Conditions:
 - tog pa0(1s), **ON**: Bandgap, LVR, IHRC
 - no** t16m, **no** interrupt, **no** floating IO pins, disable ILRC, **Touch**: Disable

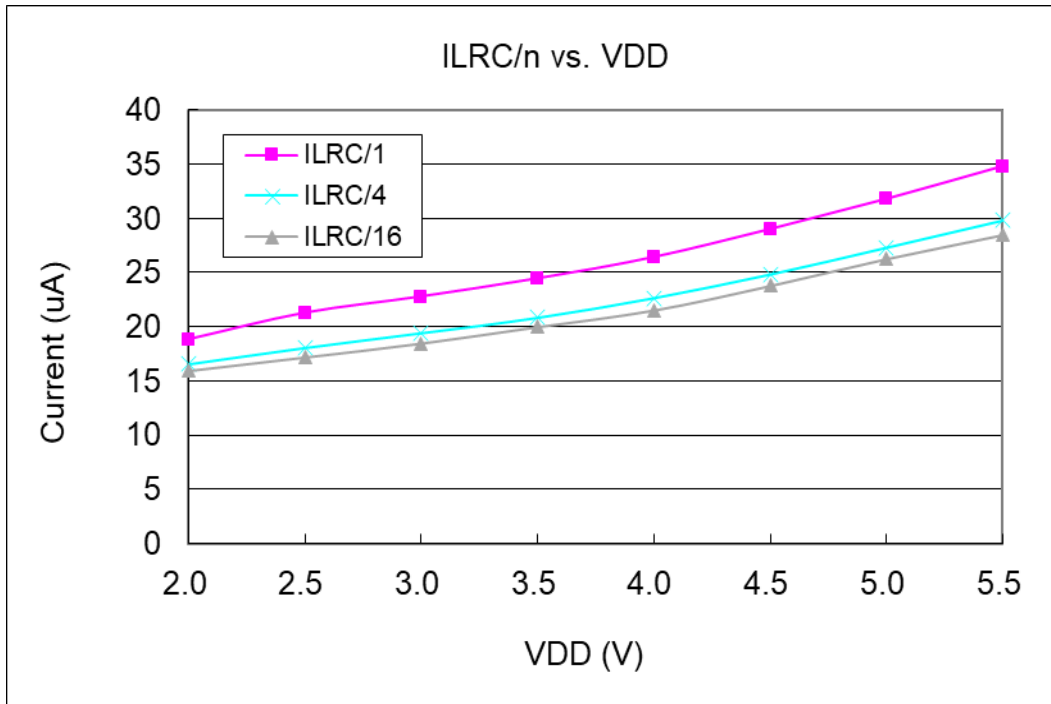

4.11. Typical IO pull high resistance

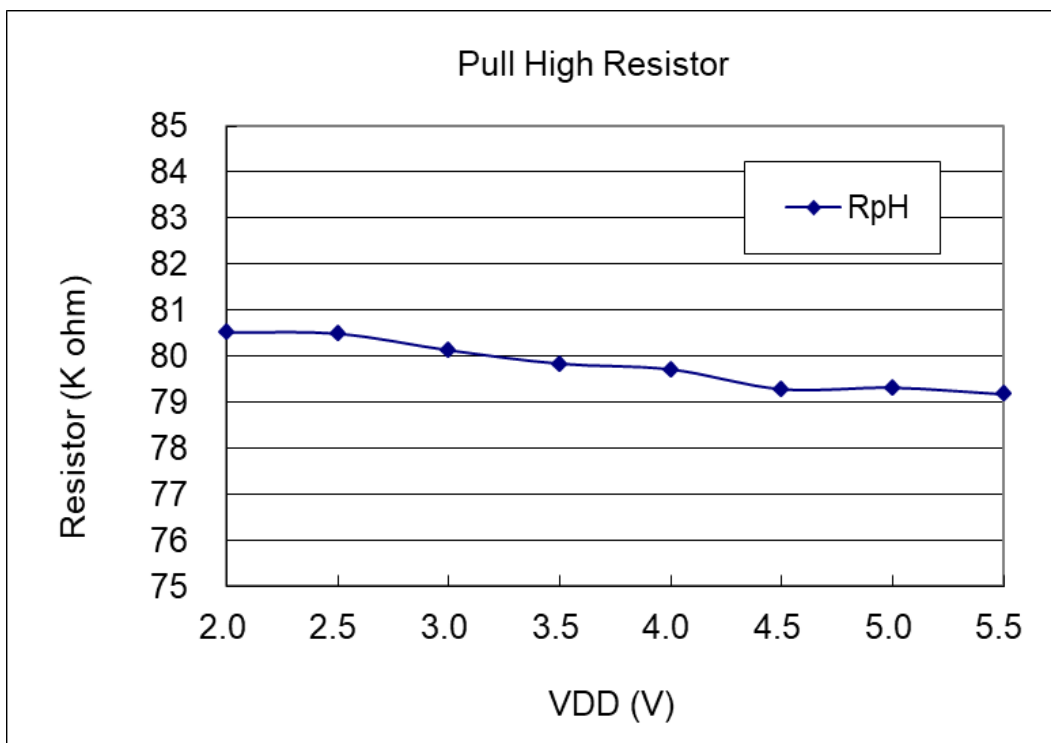

4.12. Typical IO pull low resistance

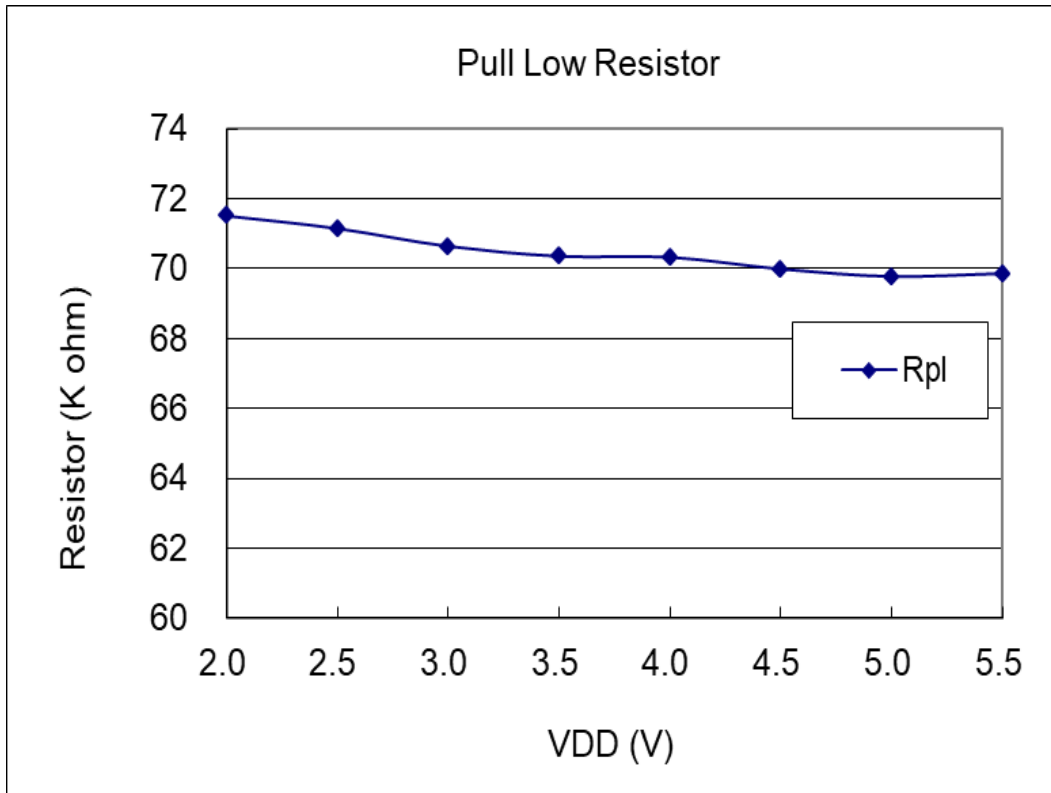

4.13. Typical IO driving current (I_{OH}) and sink current (I_{OL}) ($V_{OH}=0.9*V_{DD}$, $V_{OL}=0.1*V_{DD}$)

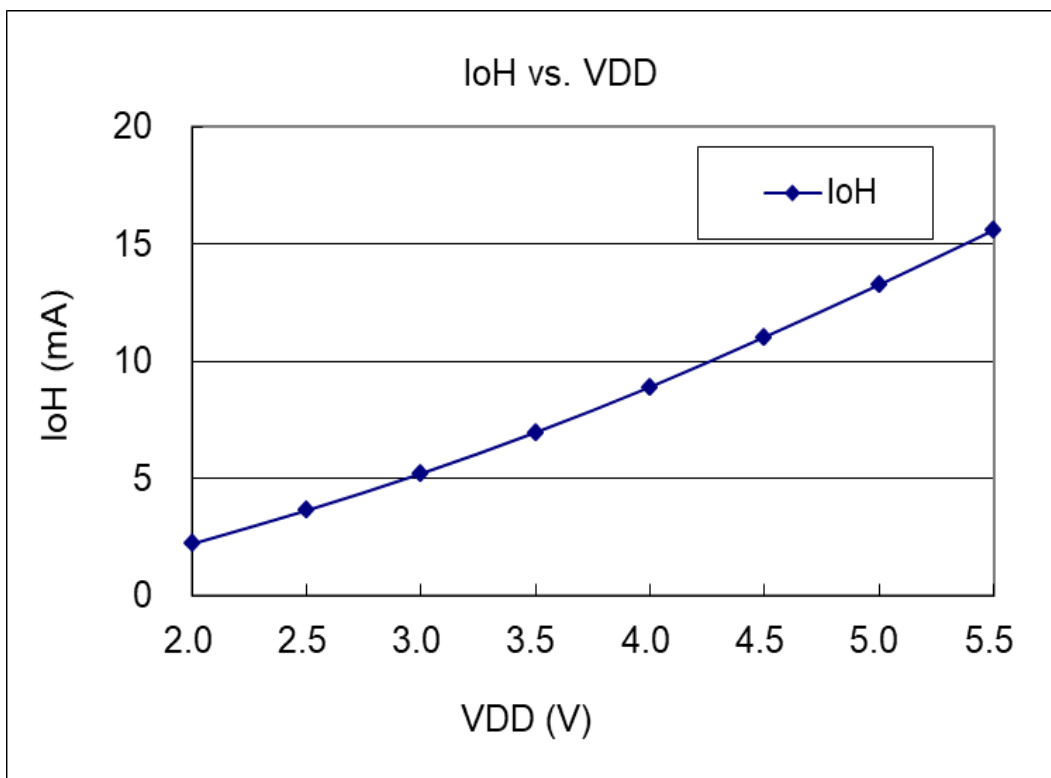

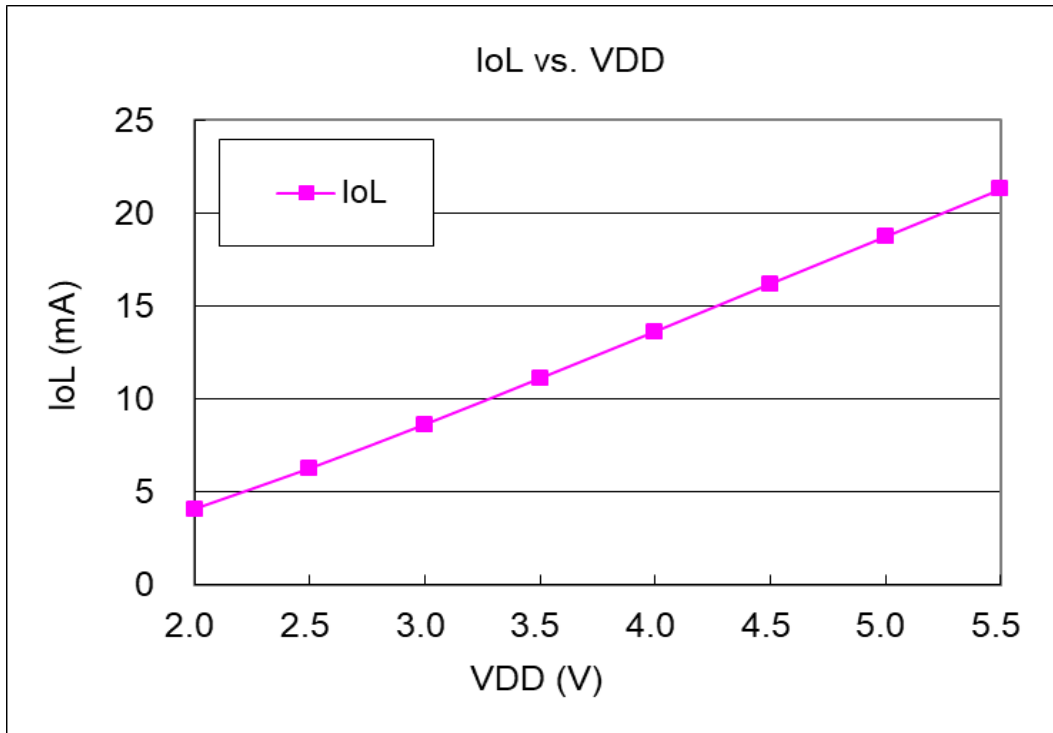

4.14. Typical IO input high/ low threshold voltage (V_{IH} / V_{IL})

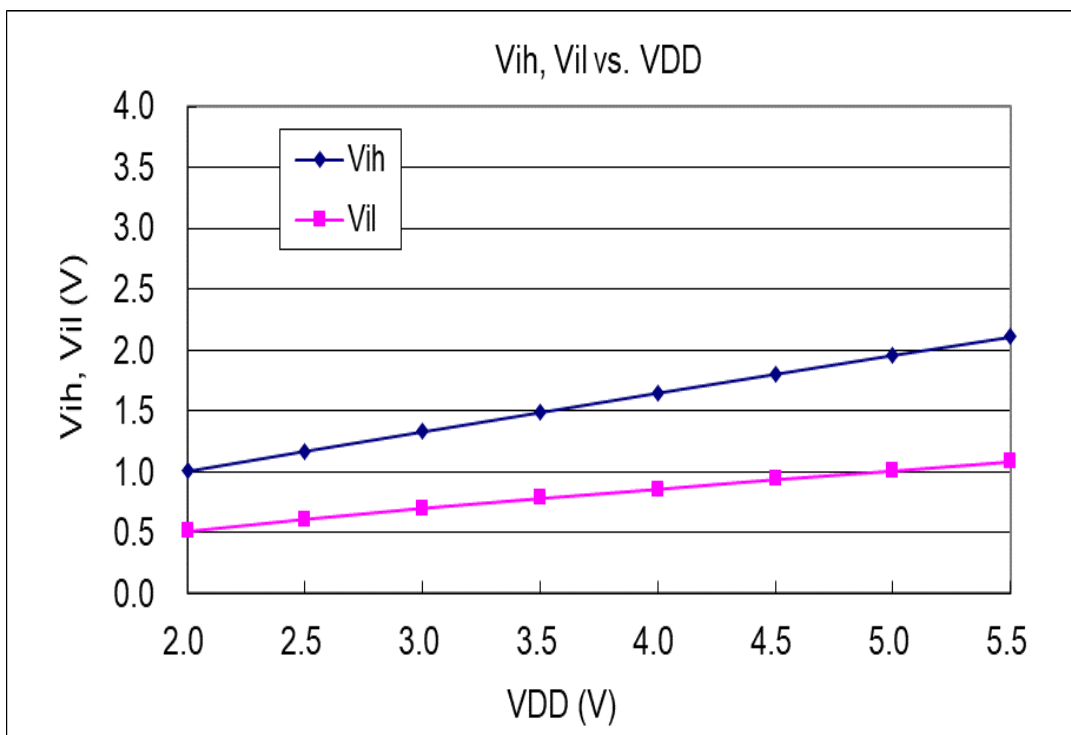

4.15. Typical power down current (I_{PD}) and power save current (I_{PS})

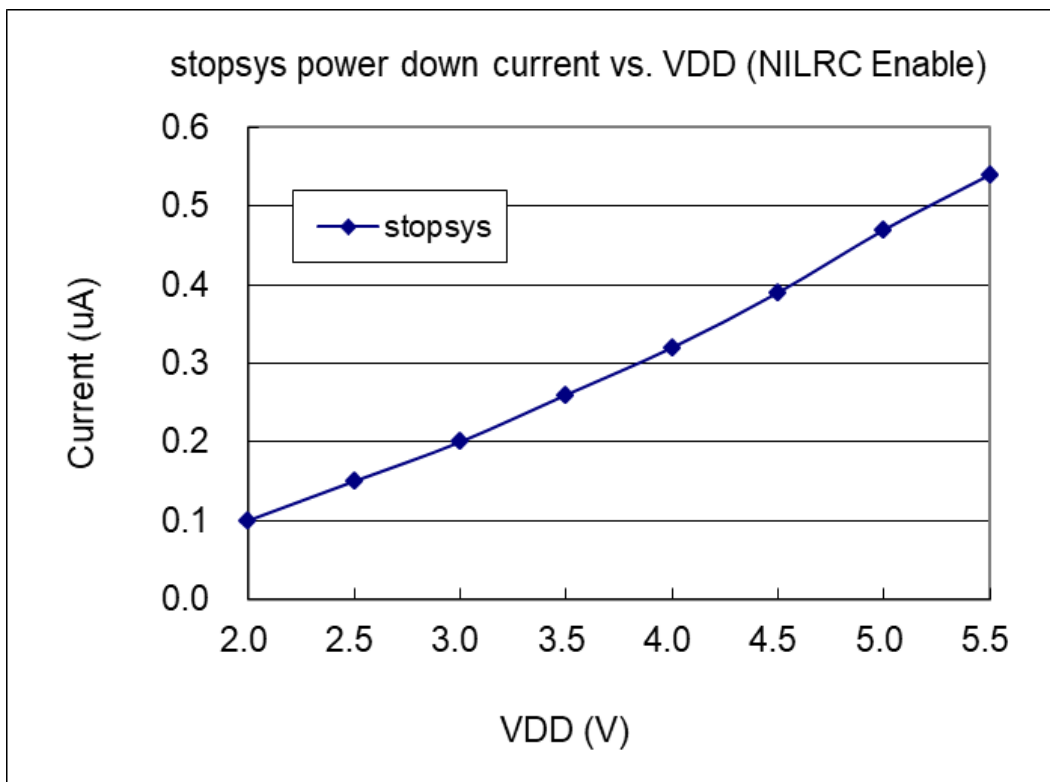
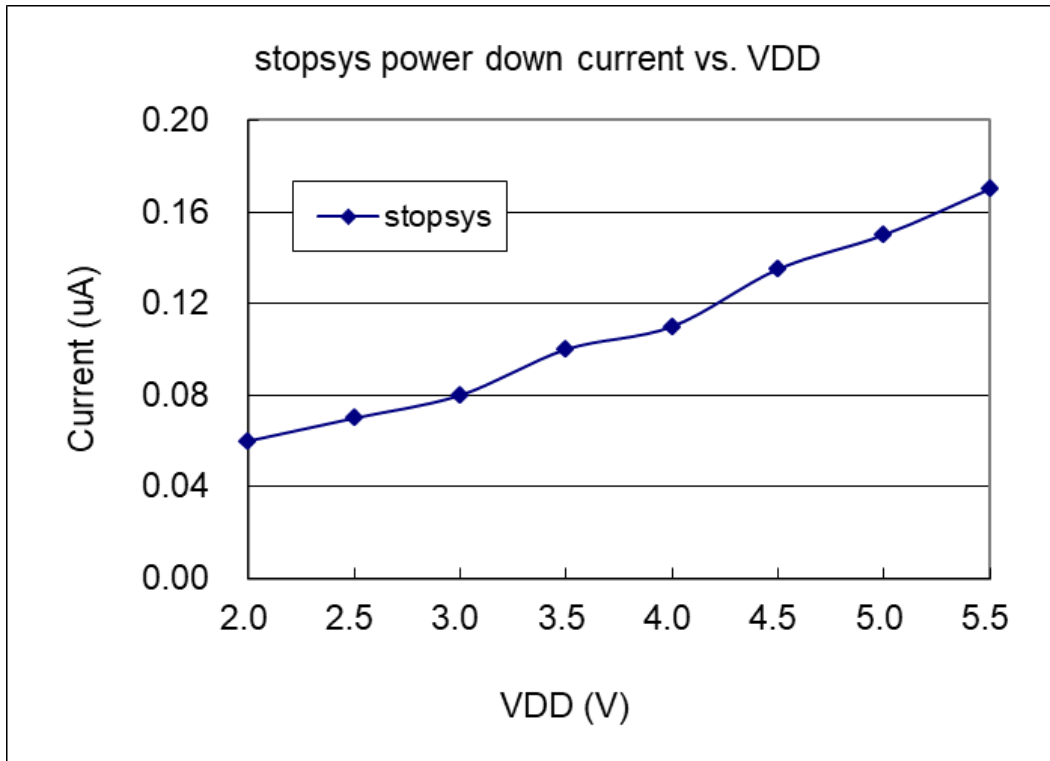

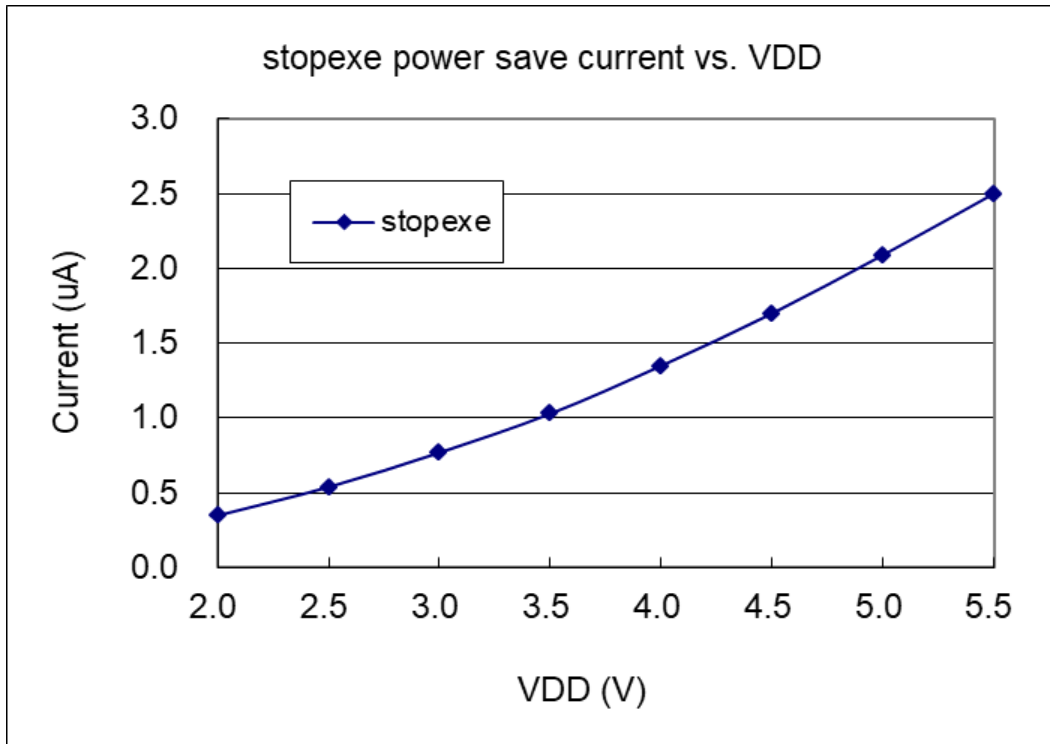

5. Functional Description

5.1. Program Memory – OTP

The OTP (One Time Programmable) program memory is used to store the program instructions to be executed. The OTP program memory may contain the data, tables and interrupt entry. After reset, the initial address for FPP0 is 0x000. The interrupt entry is 0x010 if used. The OTP program memory for PMS161 is a 1.5KW that is partitioned as Table 1. The OTP memory from address 0x5E0 to 0x5FF is for system using, address space from 0x001 to 0x00F and from 0x011 to 0x5DF is user program space.

Address	Function
0x000	FPP0 reset – goto instruction
0x001	User program
•	•
•	•
0x00F	User program
0x010	Interrupt entry address
0x011	User program
•	•
0x5DF	User program
0x5E0	System Using
•	•
0x5FF	System Using

Table 1: Program Memory Organization

5.2. Boot Up

POR (Power-On-Reset) is used to reset PMS161 when power up. The boot up time is 3000 ILRC clock cycles. Customer must ensure the stability of supply voltage after power up no matter which option is chosen, the power up sequence is shown in the Fig. 2 and t_{SBP} is the boot up time.

Please noted, during Power-On-Reset, the V_{DD} must go higher than V_{POR} to boot-up the MCU.

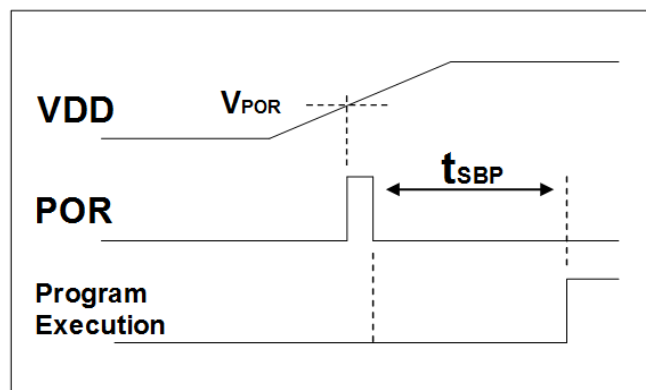

Boot up from Power-On Reset

Fig. 2: Power Up Sequence

5.3. Data Memory – SRAM

The access of data memory can be byte or bit operation. Besides data storage, the SRAM data memory is also served as data pointer of indirect access method and the stack memory.

The stack memory is defined in the data memory. The stack pointer is defined in the stack pointer register; the depth of stack memory of each processing unit is defined by the user. The arrangement of stack memory fully flexible and can be dynamically adjusted by the user.

For indirect memory access mechanism, the data memory is used as the data pointer to address the data byte. All the data memory could be the data pointer; it's quite flexible and useful to do the indirect memory access. All the 96 bytes data memory of PMS161 can be accessed by indirect access mechanism.

5.4. Oscillator and clock

There are two oscillator circuits provided by PMS161: internal high RC oscillator (IHRC) and internal low RC oscillator (ILRC), and these two oscillators are enabled or disabled by registers `clkmd.4` and `clkmd.2` independently. User can choose one of these two oscillators as system clock source and use ***clkmd*** register to target the desired frequency as system clock to meet different application.

Oscillator Module	Enable/Disable
IHRC	<code>clkmd.4</code>
ILRC	<code>clkmd.2</code>

Table 2: Oscillator Module

5.4.1. Internal High RC oscillator and Internal Low RC oscillator

After boot-up, only the ILRC oscillators are enabled. The frequency of IHRC can be calibrated to eliminate process variation by ***ihrcr*** register; normally it is calibrated to 16MHz. Please refer to the measurement chart for IHRC frequency verse V_{DD} and IHRC frequency verse temperature.

The frequency of ILRC will vary by process, supply voltage and temperature, please refer to DC specification and do not use for accurate timing application.

5.4.2. IHRC calibration

The IHRC frequency may be different chip by chip due to manufacturing variation, PMS161 provide the IHRC frequency calibration to eliminate this variation, and this function can be selected when compiling user's program and the command will be inserted into user's program automatically. The calibration command is shown as below:

```
.ADJUST_IC    SYSCLK=IHRC/(p1), IHRC=(p2)MHz, VDD=(p3)V
```

Where,

p1=2, 4, 8, 16, 32; In order to provide different system clock.

p2=14 ~ 18; In order to calibrate the chip to different frequency, 16MHz is the usually one.

p3=2.3 ~ 5.5; In order to calibrate the chip under different supply voltage.

5.4.3. IHRC Frequency Calibration and System Clock

During compiling the user program, the options for IHRC calibration and system clock are shown as Table 3:

SYSCLK	CLKMD	IHRCR	Description
○ Set IHRC / 2	= 34h (IHRC / 2)	Calibrated	IHRC calibrated to 16MHz, CLK=8MHz (IHRC/2)
○ Set IHRC / 4	= 14h (IHRC / 4)	Calibrated	IHRC calibrated to 16MHz, CLK=4MHz (IHRC/4)
○ Set IHRC / 8	= 3Ch (IHRC / 8)	Calibrated	IHRC calibrated to 16MHz, CLK=2MHz (IHRC/8)
○ Set IHRC / 16	= 1Ch (IHRC / 16)	Calibrated	IHRC calibrated to 16MHz, CLK=1MHz (IHRC/16)
○ Set IHRC / 32	= 7Ch (IHRC / 32)	Calibrated	IHRC calibrated to 16MHz, CLK=0.5MHz (IHRC/32)
○ Set ILRC	= E4h (ILRC / 1)	Calibrated	IHRC calibrated to 16MHz, CLK=ILRC
○ Disable	No change	No Change	IHRC not calibrated, CLK not changed

Table 3: Options for IHRC Frequency Calibration

Usually, .ADJUST_IC will be the first command after boot up, in order to set the target operating frequency whenever starting the system. The program code for IHRC frequency calibration is executed only one time that occurs in writing the codes into OTP memory; after then, it will not be executed again. If the different option for IHRC calibration is chosen, the system status is also different after boot. The following shows the status of PMS161 for different option:

- (1) .ADJUST_IC SYSCLK=IHRC/2, IHRC=16MHz, V_{DD}=5V
 After boot up, CLKMD = 0x34:
 - ◆ IHRC frequency is calibrated to 16MHz@V_{DD}=5V and IHRC module is enabled
 - ◆ System CLK = IHRC/2 = 8MHz
 - ◆ Watchdog timer is disabled, ILRC is enabled, PA5 is in input mode

- (2) .ADJUST_IC SYSCLK=IHRC/4, IHRC=16MHz, V_{DD}=3.3V
 After boot up, CLKMD = 0x14:
 - ◆ IHRC frequency is calibrated to 16MHz@V_{DD}=3.3V and IHRC module is enabled
 - ◆ System CLK = IHRC/4 = 4MHz
 - ◆ Watchdog timer is disabled, ILRC is enabled, PA5 is in input mode

- (3) .ADJUST_IC SYSCLK=IHRC/8, IHRC=16MHz, V_{DD}=2.5V
 After boot up, CLKMD = 0x3C:
 - ◆ IHRC frequency is calibrated to 16MHz@V_{DD}=2.5V and IHRC module is enabled
 - ◆ System CLK = IHRC/8 = 2MHz
 - ◆ Watchdog timer is disabled, ILRC is enabled, PA5 is in input mode

- (4) .ADJUST_IC SYSCLK=IHRC/16, IHRC=16MHz, V_{DD}=2.3V
 After boot up, CLKMD = 0x1C:
 - ◆ IHRC frequency is calibrated to 16MHz@V_{DD}=2.3V and IHRC module is enabled
 - ◆ System CLK = IHRC/16 = 1MHz
 - ◆ Watchdog timer is disabled, ILRC is enabled, PA5 is in input mode

- (5) .ADJUST_IC SYSCLK=IHRC/32, IHRC=16MHz, V_{DD}=5V
 After boot up, CLKMD = 0x7C:
 - ◆ IHRC frequency is calibrated to 16MHz@V_{DD}=5V and IHRC module is enabled
 - ◆ System CLK = IHRC/32 = 500KHz
 - ◆ Watchdog timer is disabled, ILRC is enabled, PA5 is in input mode

- (6) `.ADJUST_IC` `SYSCLK=ILRC, IHRC=16MHz, VDD=5V`
 After boot up, `CLKMD = 0XE4`:
- ◆ IHRC frequency is calibrated to 16MHz@VDD=5V and IHRC module is disabled
 - ◆ System CLK = ILRC
 - ◆ Watchdog timer is disabled, ILRC is enabled, PA5 is input mode
- (7) `.ADJUST_IC` `DISABLE`
 After boot up, `CLKMD` is not changed (Do nothing):
- ◆ IHRC is not calibrated and IHRC module is disabled
 - ◆ System CLK = ILRC
 - ◆ Watchdog timer is enabled, ILRC is enabled, PA5 is input mode

5.4.4. System Clock and LVR levels

The clock source of system clock comes from IHRC or ILRC, the hardware diagram of system clock in the PMS161 is shown as Fig. 3.

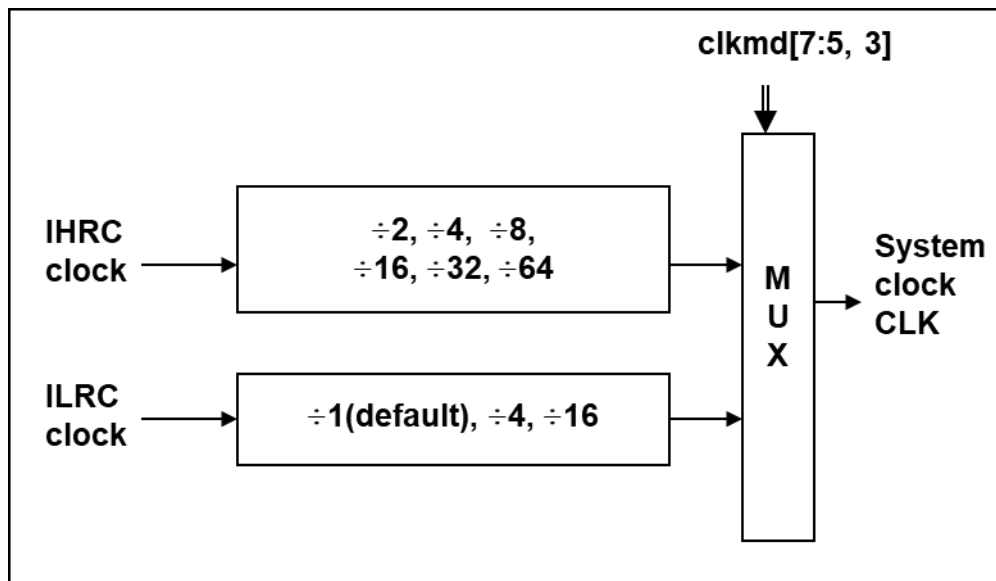

Fig. 3: Options of System Clock

User can choose different operating system clock depends on its requirement; the selected operating system clock should be combined with supply voltage and LVR level to make system stable. The LVR level will be selected during compilation, and the lowest LVR levels can be chosen for different operating frequencies. Please refer to Section 4.1.

5.4.5. System Clock Switching

After IHRC calibration, user may want to switch system clock to a new frequency or may switch system clock at any time to optimize the system performance and power consumption. Basically, the system clock of PMS161 can be switched among IHRC and ILRC by setting the **clkmd** register at any time; system clock will be the new one after writing to **clkmd** register immediately. Please notice that the original clock module can NOT be turned off at the same time as writing command to **clkmd** register. The examples are shown as below and more information about clock switching, please refer to the “Help” → “Application Note” → “IC Introduction” → “Register Introduction” → CLKMD”.

Case 1: Switching system clock from ILRC to IHRC/2

```

... // system clock is ILRC
CLKMD.4 = 1; // turn on IHRC first to improve anti-interference ability
CLKMD = 0x34 ; // switch to IHRC/2 · ILRC CAN NOT be disabled here
// CLKMD.2 = 0 ; // if need, ILRC CAN be disabled at this time
...

```

Case 2: Switching system clock from IHRC/2 to ILRC

```

... // system clock is IHRC/2
CLKMD = 0xF4 ; // switch to ILRC, IHRC CAN NOT be disabled here
CLKMD.4 = 0 ; // IHRC CAN be disabled at this time
...

```

Case 3: Switching system clock from IHRC/2 to IHRC/4

```

... // system clock is IHRC/2, ILRC is enabled here
CLKMD = 0X14 ; // switch to IHRC/4
...

```

Case 4: System may hang if it is to switch clock and turn off original oscillator at the same time

```

... // system clock is ILRC
CLKMD = 0x30 ; // CAN NOT switch clock from ILRC to IHRC/2 and turn off ILRC oscillator at the same time

```

5.5. Comparator

One hardware comparator is built inside the PMS161; Fig.4 shows its hardware diagram. It can compare signals between two pins or with either internal reference voltage $V_{\text{internal R}}$ or internal bandgap reference voltage. The two signals to be compared, one is the plus input and the other one is the minus input. For the minus input of comparator can be PA3, PA4, Internal bandgap 1.20 volt, or $V_{\text{internal R}}$ selected by bit [3:1] of gpcc register, and the plus input of comparator can be PA4 or $V_{\text{internal R}}$ selected by bit 0 of gpcc register.

The comparator result can be selected through gpcs.7 to forcibly output to PA0 whatever input or output state. It can be a direct output or sampled by Timer2 clock (TM2_CLK) which comes from Timer2 module. The output polarity can be also inverted by setting gpcc.4 register. The comparator output can be used to request interrupt service or read through gpcc.6.

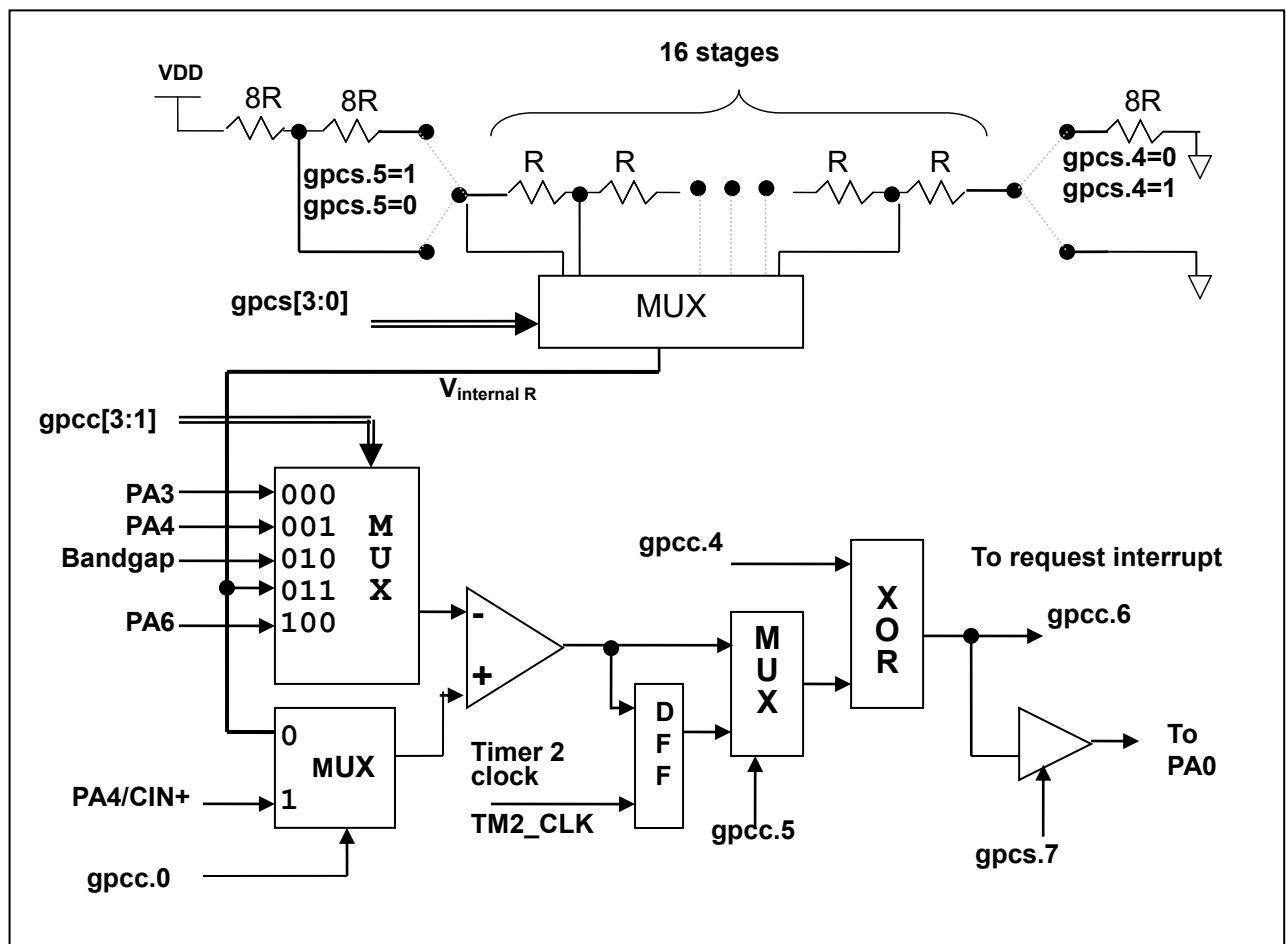

Fig.4: Hardware diagram of comparator

5.5.1. Internal reference voltage ($V_{\text{internal R}}$)

The internal reference voltage $V_{\text{internal R}}$ is built by series resistance to provide different level of reference voltage, bit 4 and bit 5 of **gpcs** register are used to select the maximum and minimum values of $V_{\text{internal R}}$ and bit [3:0] of **gpcs** register are used to select one of the voltage levels which is divided-by-16 from the defined maximum level to minimum level. Fig.5 to Fig.8 shows four conditions to have different reference voltage $V_{\text{internal R}}$. By setting the **gpcs** register, the internal reference voltage $V_{\text{internal R}}$ can be ranged from $(1/32)*V_{\text{DD}}$ to $(3/4)*V_{\text{DD}}$.

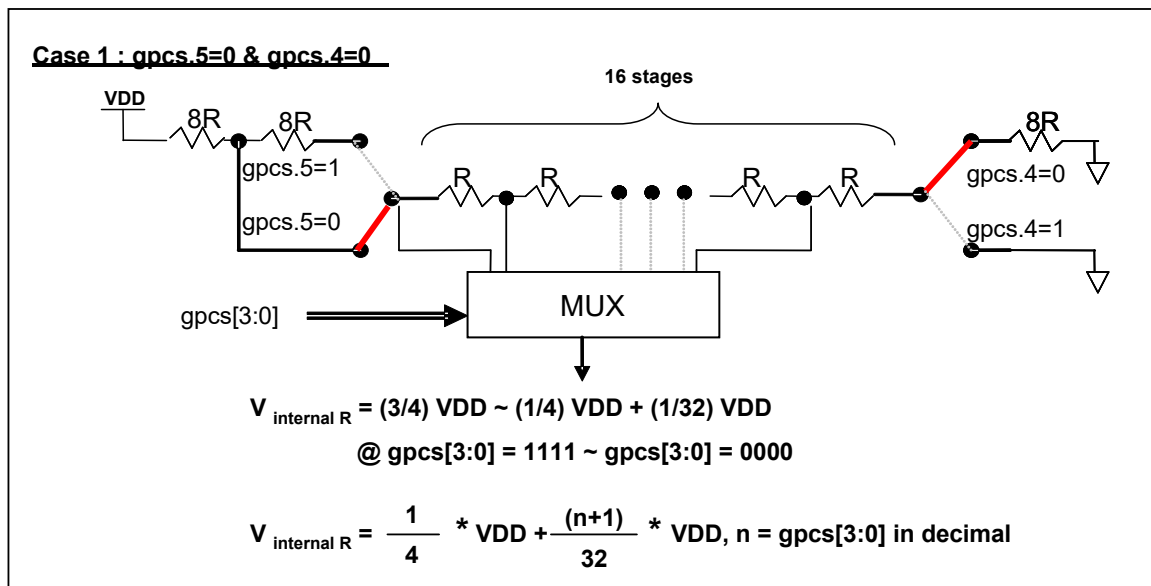

Fig.5: $V_{\text{internal R}}$ hardware connection if gpcs.5=0 and gpcs.4=0

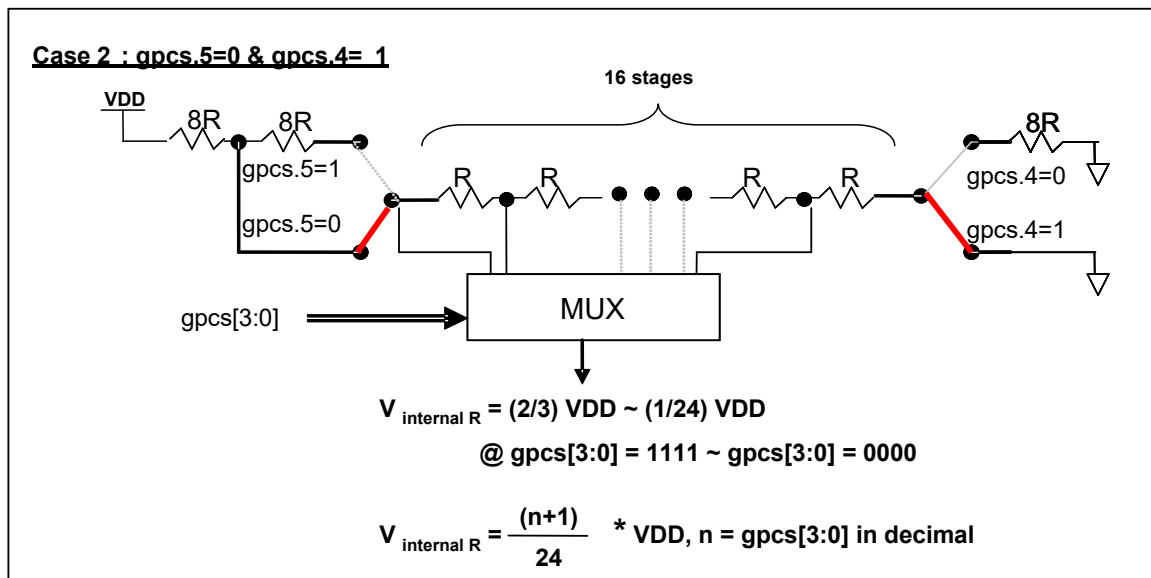

Fig.6: $V_{\text{internal R}}$ hardware connection if gpcs.5=0 and gpcs.4=1

PMS161

5-ch Touch Keys OTP Controller

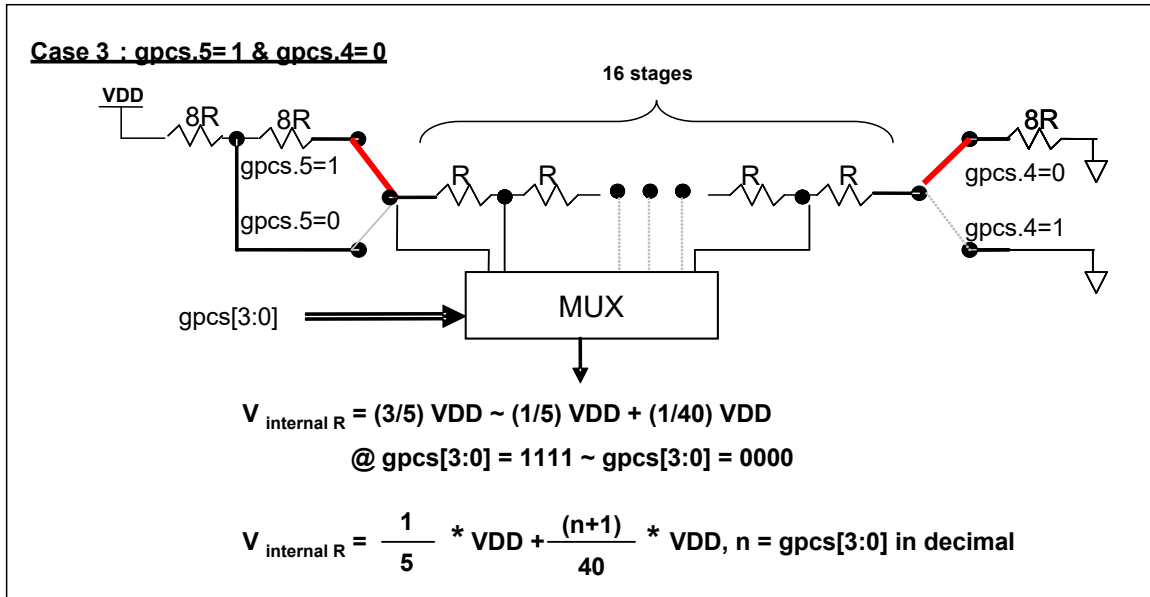

Fig.7: $V_{\text{internal R}}$ hardware connection if gpcs.5=1 and gpcs.4=0

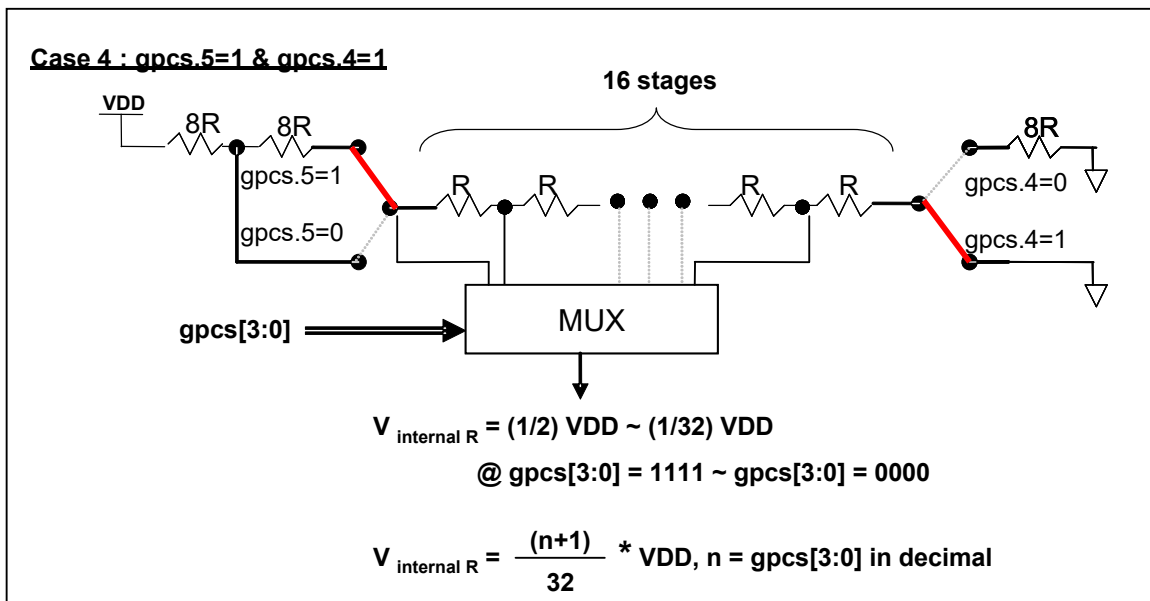

Fig.8: $V_{\text{internal R}}$ hardware connection if gpcs.5=1 and gpcs.4=1

5.5.2. Using the comparator

Case1:

Choosing PA3 as minus input and $V_{internal R}$ with $(18/32)*V_{DD}$ voltage level as plus input, $V_{internal R}$ is configured as the above Figure “gpcs[5:4] = 2b'00” and gpcs [3:0] = 4b'1001 (n=9) to have $V_{internal R} = (1/4)*V_{DD} + [(9+1)/32]*V_{DD} = [(9+9)/32]*V_{DD} = (18/32)*V_{DD}$.

```

gpcs = 0b1_0_00_1001;           //  $V_{internal R} = V_{DD}*(18/32)$ 
gpcc = 0b1_0_0_0_000_0;         // enable comp, - input: PA3, + input:  $V_{internal R}$ 
padier = 0bxxxx_0_xxx;          // disable PA3 digital input to prevent leakage current

```

or

```

$ GPCS  $V_{DD}*18/32$ ;
$ GPCC Enable, N_PA3, P_R;     // - input: N_xx , + input: P_R( $V_{internal R}$ )
PADIER = 0bxxxx_0_xxx;

```

Case 2:

Choosing $V_{internal R}$ as minus input with $(22/40)*V_{DD}$ voltage level and PA4 as plus input, the comparator result will be inversed and then output to PA0. $V_{internal R}$ is configured as the above Figure “gpcs[5:4] = 2b'10” and gpcs [3:0] = 4b'1101 (n=13) to have $V_{internal R} = (1/5)*V_{DD} + [(13+1)/40]*V_{DD} = [(13+9)/40]*V_{DD} = (22/40)*V_{DD}$.

```

gpcs = 0b1_0_1_0_1101;           // output to PA0,  $V_{internal R} = V_{DD}*(22/40)$ 
gpcc = 0b1_0_0_1_011_1;         // Inverse output, - input:  $V_{internal R}$ , + input: PA4
padier = 0bxxx_0_xxxx;          // disable PA4 digital input to prevent leakage current

```

or

```

$ GPCS Output,  $V_{DD}*22/40$ ;
$ GPCC Enable, Inverse, N_R, P_PA4; // - input: N_R( $V_{internal R}$ ) , + input: P_xx
PADIER = 0bxxx_0_xxxx;

```

Note: When selecting output to PA0 output, GPCS will affect the PA3 output function in ICE. Though the IC is fine, be careful to avoid this error during emulation.

5.5.3. Using the comparator and Bandgap 1.20V

The internal bandgap module can provide 1.20 volt; it can measure the external supply voltage level. The bandgap 1.20 volt is selected as minus input of comparator and $V_{\text{internal R}}$ is selected as plus input, the supply voltage of $V_{\text{internal R}}$ is V_{DD} , the V_{DD} voltage level can be detected by adjusting the voltage level of $V_{\text{internal R}}$ to compare with bandgap. If N (gpcs[3:0] in decimal) is the number to let $V_{\text{internal R}}$ closest to bandgap 1.20 volt, the supply voltage V_{DD} can be calculated by using the following equations:

For using Case 1: $V_{\text{DD}} = [32 / (N+9)] * 1.20 \text{ volt} ;$

For using Case 2: $V_{\text{DD}} = [24 / (N+1)] * 1.20 \text{ volt} ;$

For using Case 3: $V_{\text{DD}} = [40 / (N+9)] * 1.20 \text{ volt} ;$

For using Case 4: $V_{\text{DD}} = [32 / (N+1)] * 1.20 \text{ volt} ;$

More information and sample code, please refer to IDE utility.

Case 1:

```

$ GPCS  VDD*12/40;           // 4.0V * 12/40 = 1.2V
$ GPCC  Enable, BANDGAP, P_R; // - input: BANDGAP, + input: P_R(Vinternal R)
....
if (GPC_Out)                 // or GPCC.6
{                             // when VDD> 4V
}
else
{                             // when VDD< 4V
}

```

5.6. 16-bit Timer (Timer16)

PMS161 provide a 16-bit hardware timer (Timer16) and its clock source may come from system clock (CLK), internal high RC oscillator (IHRC), internal low RC oscillator (ILRC), PA0 or PA4. Before sending clock to the 16-bit counter, a pre-scaling logic with divided-by-1, 4, 16 or 64 is selectable for wide range counting. The 16-bit counter performs up-counting operation only, the counter initial values can be stored from data memory by issuing the **stt16** instruction and the counting values can be loaded to data memory by issuing the **ldt16** instruction. The interrupt request from Timer16 will be triggered by the selected bit which comes from bit[15:8] of this 16-bit counter, rising edge or falling edge can be optional chosen by register **integs.4**. The hardware diagram of Timer16 is shown as Fig. 9.

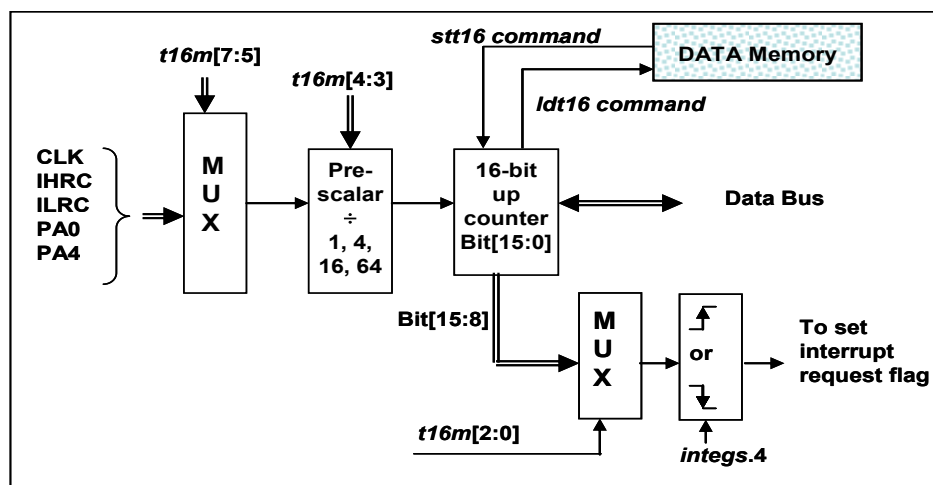

Fig. 9: Hardware diagram of Timer16

When using the Timer16, the syntax for Timer16 has been defined in the .INC file. There are three parameters to define the Timer16 using; 1st parameter is used to define the clock source of Timer16, 2nd parameter is used to define the pre-scalar and the 3rd one is to define the interrupt source.

```

T16M IO_RW 0x06
$ 7~5: STOP, SYSCLK, X, PA4_F, IHRC, X, ILRC, PA0_F // 1st par.
$ 4~3: /1, /4, /16, /64 // 2nd par.
$ 2~0: BIT8, BIT9, BIT10, BIT11, BIT12, BIT13, BIT14, BIT15 // 3rd par.

```

User can choose the proper parameters of T16M to meet system requirement, examples as below:

```

$ T16M SYSCLK, /64, BIT15;
// choose (SYSCLK/64) as clock source, every 2^16 clock to set INTRQ.2=1
// if system clock SYSCLK = IHRC / 2 = 8 MHz
// SYSCLK/64 = 8 MHz/64 = 8 uS, about every 524 mS to generate INTRQ.2=1

$ T16M PA0, /1, BIT8;
// choose PA0 as clock source, every 2^9 to generate INTRQ.2=1
// receiving every 512 times PA0 to generate INTRQ.2=1

$ T16M STOP;
// stop Timer16 counting

```

5.7. Watchdog Timer

The watchdog timer (WDT) is a counter with clock coming from ILRC. There are four different timeout periods of watchdog timer can be chosen by setting the *misc* register, it is:

- ◆ 8k ILRC clocks period if register *misc*[1:0]=00 (default)
- ◆ 16k ILRC clocks period if register *misc*[1:0]=01
- ◆ 64k ILRC clocks period if register *misc*[1:0]=10
- ◆ 256k ILRC clocks period if register *misc*[1:0]=11

The frequency of ILRC may drift a lot due to the variation of manufacture, supply voltage and temperature; user should reserve guard band for safe operation. Besides, the watchdog period will also be shorter than expected after Reset or Wakeup events. It is suggested to clear WDT by *wdreset* command after these events to ensure enough clock periods before WDT timeout.

When WDT is timeout, PMS161 will be reset to restart the program execution. The relative timing diagram of watchdog timer is shown as Fig.10.

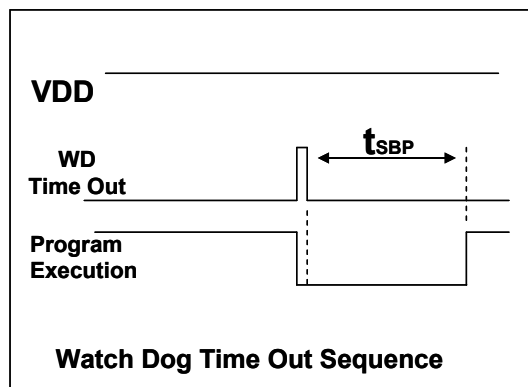

Fig. 10: Sequence of Watch Dog Time Out

5.8. Interrupt

There are seven interrupt lines for PMS161:

- ◆ External interrupt PA0 / PA5
- ◆ Timer16 interrupt
- ◆ Timer2 interrupt
- ◆ Timer3 interrupt
- ◆ GPC interrupt
- ◆ Two touch key interrupts (TK_OV and TK_END)

Every interrupt request line has its own corresponding interrupt control bit to enable or disable it; the hardware diagram of interrupt function is shown as Fig. 11. All the interrupt request flags are set by hardware and cleared by writing *intrq* register. When the request flags are set, it can be rising edge, falling edge or both, depending on the setting of register *integs*. All the interrupt request lines are also controlled by *engint* instruction (enable global interrupt) to enable interrupt operation and *disgint* instruction (disable global interrupt) to disable it. The stack memory for interrupt is shared with data memory and its address is specified by stack register *sp*. Since the program counter is 16 bits width, the bit 0 of stack register *sp* should be kept 0. Moreover, user can use *pushaf* / *popaf* instructions to store or restore the values of *ACC* and *flag* register *to* / *from* stack memory.

Since the stack memory is shared with data memory, user should manipulate the memory using carefully. By adjusting the memory location of stack point, the depth of stack pointer could be fully specified by user to achieve maximum flexibility of system.

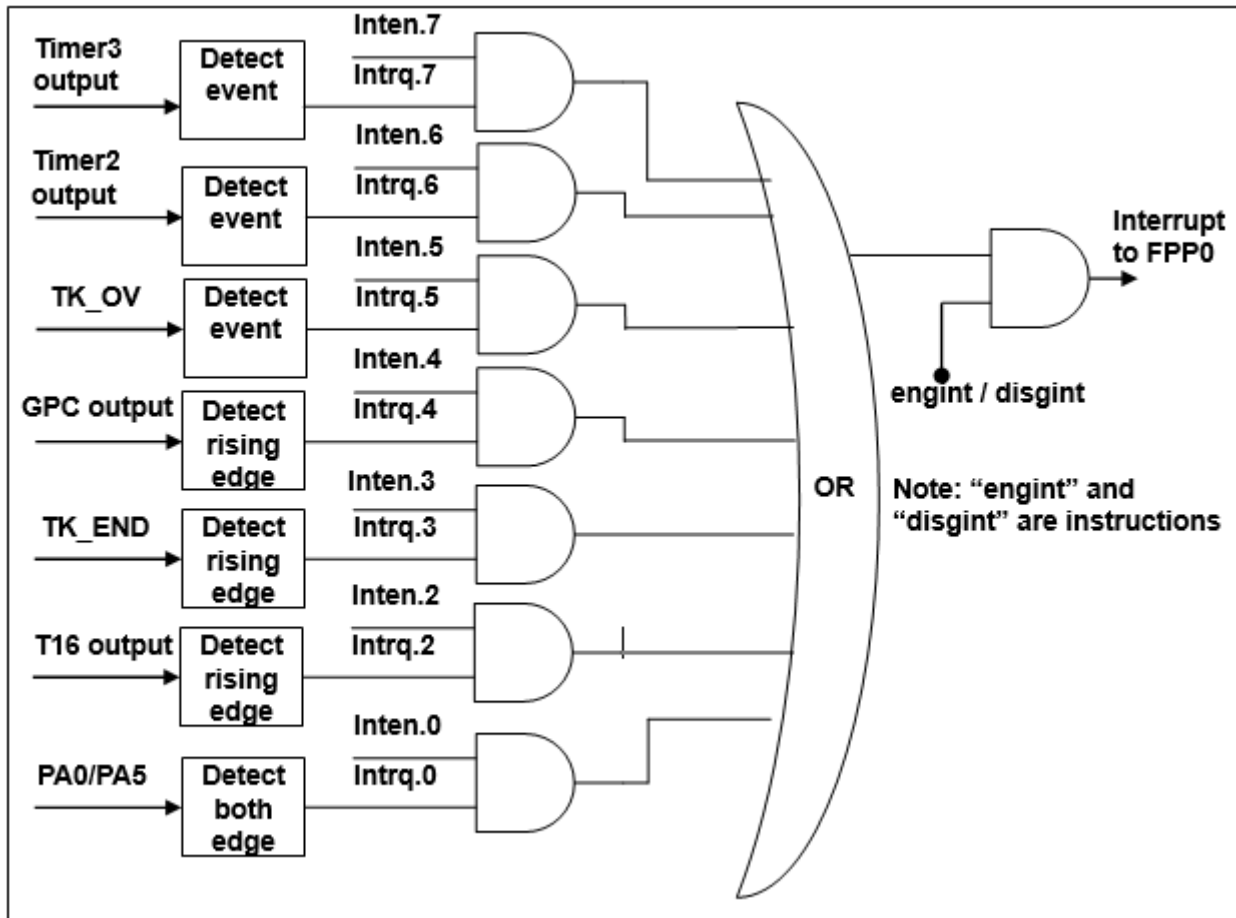

Fig. 11: Hardware diagram of Interrupt controller

Once the interrupt occurs, its operation will be:

- ◆ The program counter will be stored automatically to the stack memory specified by register *sp*.
- ◆ New *sp* will be updated to *sp+2*.
- ◆ Global interrupt will be disabled automatically.
- ◆ The next instruction will be fetched from address 0x010.

During the interrupt service routine, the interrupt source can be determined by reading the *intrq* register.

Note: Even if INTEN=0, INTRQ will be still triggered by the interrupt source.

After finishing the interrupt service routine and issuing the *reti* instruction to return back, its operation will be:

- ◆ The program counter will be restored automatically from the stack memory specified by register *sp*.
- ◆ New *sp* will be updated to *sp-2*.
- ◆ Global interrupt will be enabled automatically.
- ◆ The next instruction will be the original one before interrupt.

User must reserve enough stack memory for interrupt, two bytes stack memory for one level interrupt and four bytes for two levels interrupt. For interrupt operation, the following sample program shows how to handle the interrupt, noticing that it needs four bytes stack memory to handle one level interrupt and *pushaf*.

```

void      FPPA0  (void)
{
    ...
    $ INTEN PA0;           // INTEN =1; interrupt request when PA0 level changed
    INTRQ = 0;            // clear INTRQ
    ENGINT                // global interrupt enable
    ...
    DISGINT                // global interrupt disable
    ...
}

void Interrupt (void)    // interrupt service routine
{
    PUSHAF                // store ALU and FLAG register

    // If INTEN.PA0 will be opened and closed dynamically,
    // user can judge whether INTEN.PA0 =1 or not.
    // Example: If (INTEN.PA0 && INTRQ.PA0) {...}

    // If INTEN.PA0 is always enable,
    // user can omit the INTEN.PA0 judgement to speed up interrupt service routine.

    If (INTRQ.PA0)
    {
        // Here for PA0 interrupt service routine
        INTRQ.PA0 = 0;    // Delete corresponding bit (take PA0 for example)
        ...
    }
    ...
    // X: INTRQ = 0;      // It is not recommended to use INTRQ = 0 to clear all at the end of the
                        // interrupt service routine.
                        // It may accidentally clear out the interrupts that have just occurred
                        // and are not yet processed.

    POPAF                // restore ALU and FLAG register
}

```

5.9. Power-Save and Power-Down

There are three operational modes defined by hardware: ON mode, Power-Save mode and Power-Down modes. ON mode is the state of normal operation with all functions ON, Power-Save mode (“**stopexe**”) is the state to reduce operating current and CPU keeps ready to continue, Power-Down mode (“**stopsys**”) is used to save power deeply. Therefore, Power-Save mode is used in the system which needs low operating power with wake-up occasionally and Power-Down mode is used in the system which needs power down deeply with seldom wake-up. Table 4 shows the differences in oscillator modules between Power-Save mode (“**stopexe**”) and Power-Down mode (“**stopsys**”).

Differences in oscillator modules between STOPSYS and STOPEXE			
	IHRC	ILRC	NILRC
STOPSYS	Stop	Stop	No Change
STOPEXE	No Change	No Change	No Change

Table 4: Differences in oscillator modules between STOPSYS and STOPEXE

5.9.1. Power-Save mode (“**stopexe**”)

Using “**stopexe**” instruction to enter the Power-Save mode, only system clock is disabled, remaining all the oscillator modules be active. For CPU, it stops executing; however, for Timer16, counter keep counting if its clock source is not the system clock. The wake-up sources for “**stopexe**” can be IO-toggle or Timer16 counts to set values when the clock source of Timer16 is IHRC or ILRC modules, NILRC wake-up of TM3C which needs to set TM3C.0=1 to enable the NILRC or wake-up by comparator when setting GPCC.7=1 and GPCS.6=1 to enable the comparator wake-up function at the same time. Wake-up from input pins can be considered as a continuation of normal execution, the detail information for Power-Save mode shows below:

- IHRC oscillator modules: No change, keep active if it was enabled
- ILRC oscillator modules: must remain enabled, need to start with ILRC when be waking up
- System clock: Disable, therefore, CPU stops execution
- OTP memory is turned off
- Timer counter: Stop counting if system clock is selected by clock source or the corresponding oscillator module is disabled; otherwise, it keeps counting. (The Timer contains TM16, TM2, TM3)
- Wake-up sources:
 - a. IO toggle wake-up: IO toggling in digital input mode (*PxC* bit is 1 and *PxDIER* bit is 1).
 - b. Timer wake-up: If the clock source of Timer is not the SYSClk, the system will be awakened when the Timer counter reaches the set value, it is awakened on both the rising and falling edges.
 - c. TM3C wake up with NILRC clock source: it needs setting TM3C.0=1 to enable the NILRC, at the same time, the clock source of Timer3 selects NILRC.
 - d. Comparator wake-up: It needs setting *GPCC.7*=1 and *GPCS.6*=1 to enable the comparator wake-up function at the same time. Please note: the internal 1.20V bandgap reference voltage is not suitable for the comparator wake-up function.

The watchdog timer must be disabled before issuing the “**stopexe**” command, the example is shown as below:

```

CLKMD.En_WatchDog = 0;           // disable watchdog timer
stopexe;
....
Wdreset;
CLKMD.En_WatchDog = 1;           // enable watchdog timer

```

Another example shows how to use Timer16 to wake-up from “*stopexe*”:

```

$ T16M IHRC, /1, BIT8 // Timer16 setting
...
WORD count = 0;
STT16 count;
stopexe;
...

```

The initial counting value of Timer16 is zero and the system will be wakening up after the Timer16 counts 256 IHRC clocks.

5.9.2. Power-Down mode (“*stopsys*”)

Power-Down mode is the state of deeply power-saving with turning off all the oscillator modules. By using the “*stopsys*” instruction, this chip will be put on Power-Down mode directly. It is recommending to set GPCC.7=0 to disable the comparator before the command “*stopsys*”. The following shows the internal status of PMS161 in detail when “*stopsys*” command is issued:

- All the oscillator modules are turned off
- OTP memory is turned off
- The contents of SRAM and registers remain unchanged
- Wake-up sources:
 - a. IO toggle in digital mode (PxDIER bit is 1)
 - b. NILRC wake-up of TM3C: it needs setting TM3C.0=1 to enable the NILRC at the same time, the clock source of Timer3 selects NILRC.

Wake-up from input pins can be considered as a continuation of normal execution. To minimize power consumption, all the I/O pins should be carefully manipulated before entering power-down mode. The reference sample program for power down is shown as below:

```

CMKMD = 0xF4; // Change clock from IHRC to ILRC, disable watchdog timer
CLKMD.4 = 0; // disable IHRC
...
while (1)
{
    STOPSYS; // enter power-down
    if (...) break; // if wakeup happen and check OK, then return to high speed,
    // else stay in power-down mode again.
}
CLKMD = 0x34; // Change clock from ILRC to IHRC/2

```

5.9.3. Wake-up

After entering the Power-Down or Power-Save modes, the PMS161 can be resumed to normal operation by toggling IO pins or NILRC wake-up of TM3C, Timer16/Timer2 wake-up is available for Power-Save mode ONLY. Table 5 shows the differences in wake-up sources between STOPSYS and STOPEXE.

Differences in wake-up sources between STOPSYS and STOPEXE			
	IO Toggle	NILRC wake-up of TM3C	Timer16/Timer2 wake-up
STOPSYS	Yes	Yes	No
STOPEXE	Yes	Yes	Yes

Table 5: Differences in wake-up sources between Power-Save mode and Power-Down mode

When using the IO pins to wake-up the PMS161, registers *padier* should be properly set to enable the wake-up function for every corresponding pin. The time for normal wake-up is about 3000 ILRC clocks counting from wake-up event; fast wake-up can be selected to reduce the wake-up time by *misc.5* register, and the time for fast wake-up is 45 ILRC clocks from IO toggling.

Suspend mode	Wake-up mode	Wake-up time (t_{WUP}) from IO toggle
STOPEXE suspend or STOPSYS suspend	fast wake-up	$45 * T_{ILRC}$, Where T_{ILRC} is the time period of ILRC
STOPEXE suspend or STOPSYS suspend	normal wake-up	$3000 * T_{ILRC}$, Where T_{ILRC} is the clock period of ILRC

Table 6: Differences in wake-up time between fast/normal wake-up

5.10. IO Pins

All the IO pins have the same structure. When PMS161 is put in power-down or power-save mode, every pin can be used to wake-up system by toggling its state. Therefore, those pins needed to wake-up system must be set to input mode and set the corresponding bits of registers *padier* to high. The same reason, *padier.0* should be set to high when PA0 is used as external interrupt pin.

All these pins have Schmitt-trigger input buffer and output driver with CMOS level. When it is set to output low, the pull-up resistor is turned off automatically. If user wants to read the pin state, please notice that it should be set to input mode before reading the data port; if user reads the data port when it is set to output mode, the reading data comes from data register, NOT from IO pad. As an example, Table 7 shows the configuration table of bit 0 of port A. The hardware diagram of IO buffer is also shown as Fig. 12.

<i>pa.0</i>	<i>pac.0</i>	<i>paph.0</i>	<i>papl.0</i>	Description
X	0	0	0	Input without pull-high / pull-low resistor
X	0	1	0	Input with pull-high resistor
X	0	0	1	Input with pull-low resistor
X	0	1	1	Input with pull-high resistor only
0	1	X	X	Output low without pull-high / pull-low resistor
1	1	X	X	Output high without pull-high / pull-low resistor

Table 7: PA0 Configuration Table

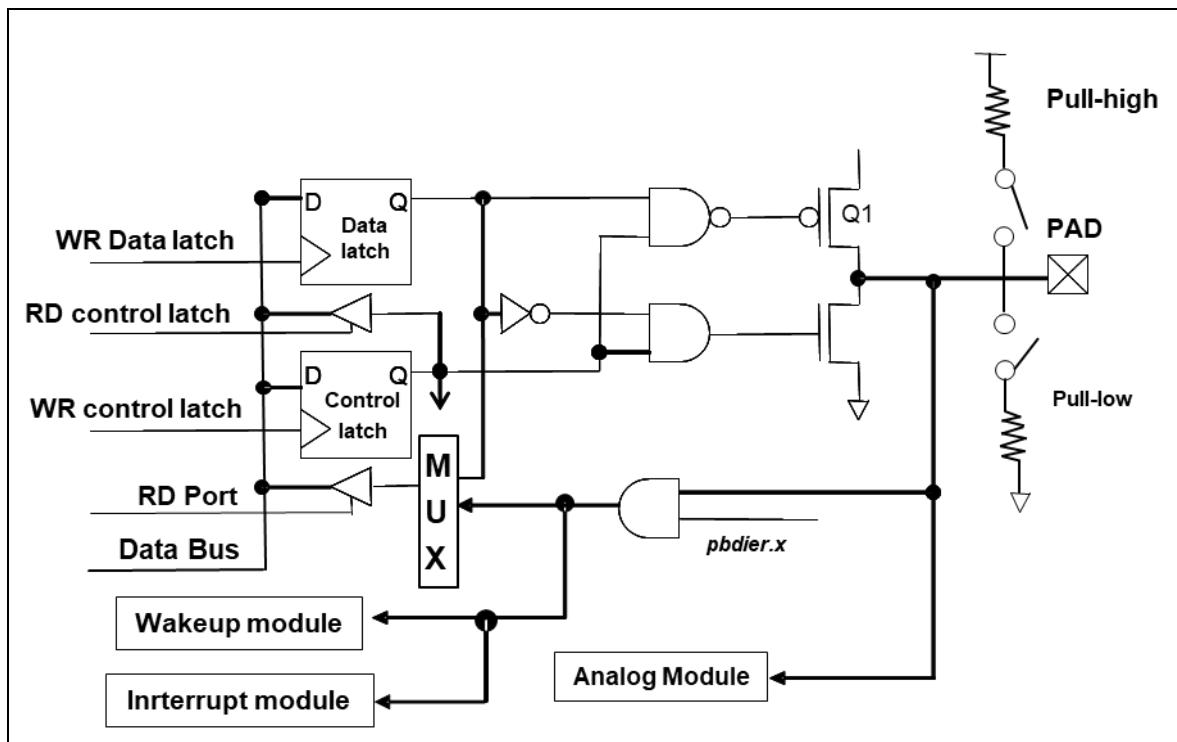

Fig. 12: Hardware diagram of IO buffer

All the IO pins have the same structure. The corresponding bits in registers *padier* should be set to low to prevent leakage current for those pins are selected to be analog function. When PMS161 is put in power-down or power-save mode, every pin can be used to wake-up system by toggling its state. Therefore, those pins needed to wake-up system must be set to input mode and set the corresponding bits of registers *padier* to high. The same reason, *padier.0* should be set to high when PA0 is used as external interrupt pin.

5.11. Reset

There are many causes to reset the PMS161, once reset is asserted, all the registers in PMS161 will be set to default values, system should be restarted once abnormal cases happen, or by jumping program counter to address 0x00.

After a power-on reset or LVR reset occurs, if VDD is greater than VDR (data storage voltage), the value of the data memory will be retained, but if the SRAM is cleared after re-power, the data cannot be retained; if VDD is less than VDR, the data the value of the memory will be turned into an unknown state that is in an indeterminate state.

If a reset occurs, and there is an instruction or syntax to clear SRAM in the program, the previous data will be cleared during program initialization and cannot be retained.

The content will be kept when reset comes from PRSTB pin or WDT timeout.

5.11.1. 8-bit Timer (Timer2)

The 8-bit hardware timer Timer2 is implemented in the PMS161, the clock sources of Timer2 may come from system clock, internal high RC oscillator (IHRC), internal low RC oscillator (ILRC), comparator, PA0 and PA4, bit [7:4] of register tm2c are used to select the clock of Timer2. A clock pre-scaling module is provided with divided-by-1, 4, 16, and 64 options, controlled by bit [6:5] of tm2s register; one scaling module with divided-by-1~32 is also provided and controlled by bit [4:0] of tm2s register. In conjunction of pre-scaling function and scaling function, the frequency of Timer2 clock (TM2_CLK) can be wide range and flexible.

The Timer2 counter performs 8-bit up-counting operation only; the counter values can be set or read back by tm2ct register. The 8-bit counter will be clear to zero automatically when its values reach for upper bound register, the upper bound register is used to define the period of timer. There are one operating modes for Timer2: period mode; period mode is used to generate periodical output waveform or interrupt event; Fig. 14 shows the timing diagram of Timer2 for period mode.

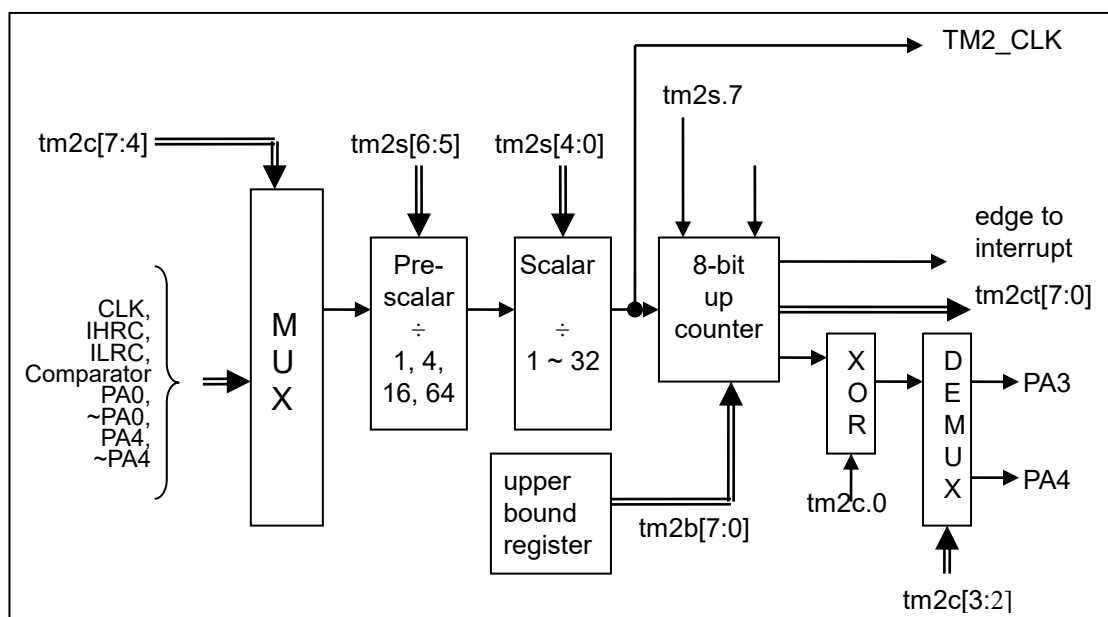
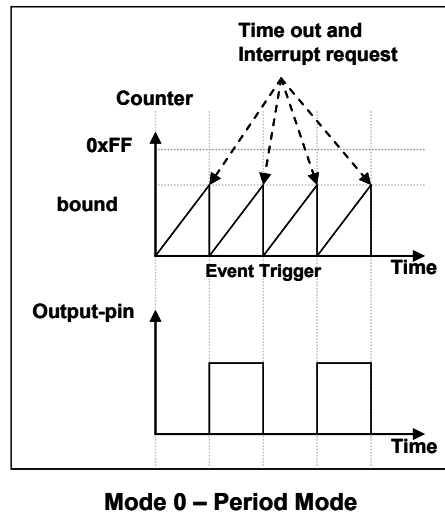

Fig. 13: Timer2 hardware diagram



Mode 0 – Period Mode

Fig. 14: Timing diagram of Timer2 in period mode

5.11.2. Using the Timer2 to generate periodical waveform

If periodical mode is selected, the duty cycle of output is always 50%; its frequency can be summarized as below:

$$\text{Frequency of Output} = Y \div [2 \times (K+1) \times S1 \times (S2+1)]$$

Where, Y = tm2c[7:4] : frequency of selected clock source

K = tm2b[7:0] : bound register in decimal

S1 = tm2s[6:5] : pre-scalar (S1= 1, 4, 16, 64)

S2 = tm2s[4:0] : scalar register in decimal (S2= 0 ~ 31)

Example 1:

tm2c = 0b0001_1000, Y=8MHz

tm2b = 0b0111_1111, K=127

tm2s = 0b0_00_00000, S1=1, S2=0

→ frequency of output = $8\text{MHz} \div [2 \times (127+1) \times 1 \times (0+1)] = 31.25\text{kHz}$

Example 2:

tm2c = 0b0001_1000, Y=8MHz

tm2b = 0b0111_1111, K=127

tm2s[7:0] = 0b0_11_11111, S1=64, S2 = 31

→ frequency = $8\text{MHz} \div (2 \times (127+1) \times 64 \times (31+1)) = 15.25\text{Hz}$

Example 3:

tm2c = 0b0001_1000, Y=8MHz

tm2b = 0b0000_1111, K=15

tm2s = 0b0_00_00000, S1=1, S2=0

→ frequency = $8\text{MHz} \div (2 \times (15+1) \times 1 \times (0+1)) = 250\text{kHz}$

Example 4:

tm2c = 0b0001_1000, Y=8MHz

tm2b = 0b0000_0001, K=1

tm2s = 0b0_00_00000, S1=1, S2=0

→ frequency = $8\text{MHz} \div (2 \times (1+1) \times 1 \times (0+1)) = 2\text{MHz}$

The sample program for using the Timer2 to generate periodical waveform to PA3 is shown as below:

```

void FPPA0 (void)
{
    . ADJUST_IC    SYSCLK=IHRC/2, IHRC=16MHz, VDD=5V
    ...
    tm2ct = 0x00;
    tm2b = 0x7f;
    tm2s = 0b0_00_00001;           // pre-scalar = 1, scalar = 2
    tm2c = 0b0001_10_0_0;         // system clock, output=PA3, period mode
    while(1)
    {
        nop;
    }
}

```

5.12. 8-bit Timer (Timer3)

The 8-bit hardware timer Timer3 is implemented in the PMS161, the clock sources of Timer3 may come from system clock, internal high RC oscillator (IHRC), internal low RC oscillator (ILRC), comparator and NILRC, bit [6:4] of register tm3c are used to select the clock of Timer3. A clock pre-scaling module is provided with divided-by-1, 4, 16, and 64 options, controlled by bit [6:5] of tm3s register; one scaling module with divided-by-1, 2, 4 is also provided and controlled by bit [1:0] of tm3s register. In conjunction of pre-scaling function and scaling function, the frequency of Timer3 clock (TM3_CLK) can be wide range and flexible.

The Timer3 counter performs 8-bit up-counting operation only; the counter values can be set or read back by tm3ct register. The 8-bit counter will be clear to zero automatically when its values reach for upper bound register, the upper bound register is used to define the period of timer. There are one operating modes for Timer3: period mode; period mode is used to generate periodical output waveform or interrupt event, Fig. 16 shows the timing diagram of Timer3 for period mode.

Bit [6:4] of register tm3c selects NILRC as clock source, which can support lower-power wake-up “stopexe” and “stopsys”. And the premise is to set tm3c.0=1 to enable the NILRC oscillator. NILRC is a slower clock than ILRC, and it is used to make a wake-up clock source with lower power consumption. NILRC estimates frequency through IHRC, which is similar to ILRC, however its frequency drift a lot. It needs to estimate frequency before it can be used. If users need related demo, please contact FAE.

PMS161

5-ch Touch Keys OTP Controller

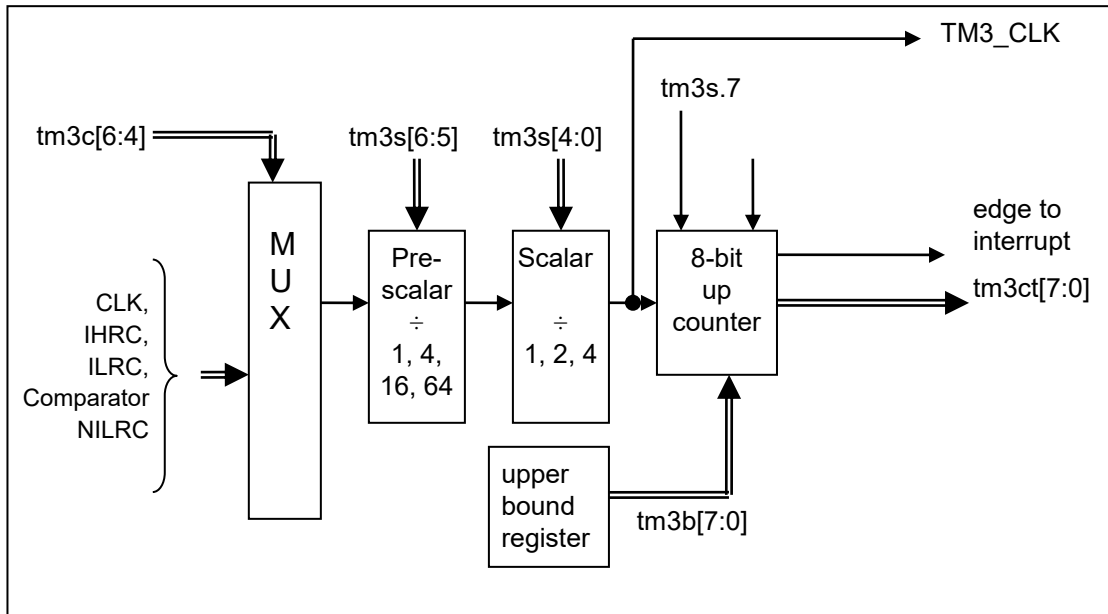
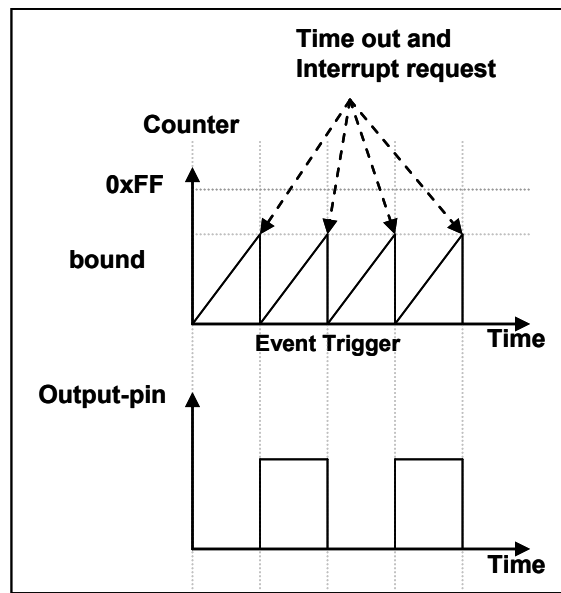

Fig. 15: Timer3 hardware diagram



Mode 0 – Period Mode

Fig. 16: Timing diagram of Timer3 in period mode

For starting touch detecting process, user should follow the procedures below:

1. Selecting the touch pad to be measure by setting TKE1 registers. Only one pad should be selected a time.
2. Issuing a Touch START command by writing "0x10" into TCC register. The capacitor CS will be automatically discharged to VSS firstly. The discharging time is selectable from 32, 64 and 128 Touch clocks by **TS[1:0]**.
3. The larger the CS capacitance value, the longer the discharge time is needed to fully discharge the capacitor to VSS. However, in some cases, 128 Touch clocks may still be not long enough to fully discharge the CS capacitor. At this time, user should do it manually by writing "0x30" into TCC register instead of "0x10". After a certain discharge time decided by the user, user can issue a Touch START (0x10) command to continue this touch conversion progress. Or user can also abort the conversion progress by writing "0x00" into TCC register.
4. After discharging, the CS will be charged toward VDD per Touch clock (TK_CLK). The charging speed is determined by the capacitance value of the selected Touch pad.
5. The charging progress will be stopped automatically when its voltage reaches the internal generated threshold voltage (VREF). The program determines whether the charging process is stopped by reading INTRQ[3]. The VREF voltage is selectable from 0.8*TP, 0.7*TP, 0.6*TP, 0.5*TP, 0.4*TP, 0.3*TP and 0.2*TP by **TS[4:2]**.
6. By reading the Touch Counter value from TKCH & TKCL registers, user can monitor the capacitance value change of the Touch pad. The value reads from Touch Counter is related to the ratio of CS and CP, while CP represents the total capacitance that is the combination of PCB, wire and touch pad whose capacitance can be varied by human finger's touch. Once the CP value is altered, the periods required to charge the CS to VREF shorten. The user can judge whether the touch pad is pressed or released by reading the difference of the touch counter.
7. The user can change the sensitivity of the touch by adjusting the value of the CS capacitor. If a CS capacitor with an excessively large value is used, the touch counter value may overflow. At this time, the INTRQ.TK_OV flag will be automatically set by the hardware, and the touch count value will continue to count from 0 again.

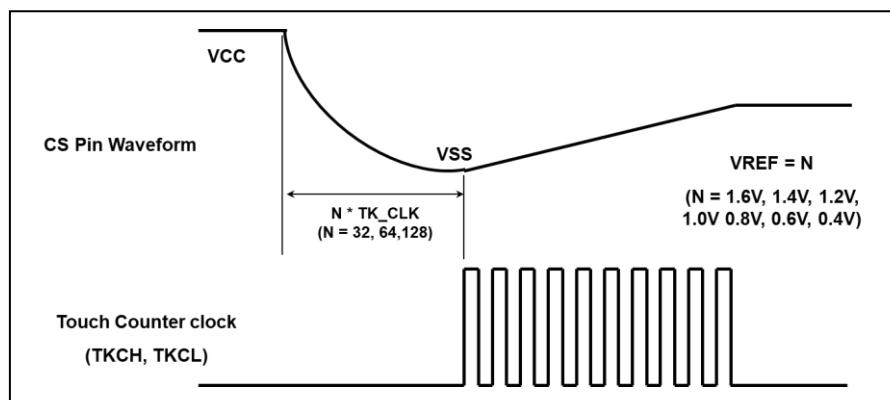

Fig. 18: Timing diagram of Touch converting progress

Note:

1. When the VREF voltage is first set or the reference voltage option is switched midway, please discard the first TKCH and TKCL data read after that.
2. Under the same conditions, the touch key count value of each IO pin may be different because of the capacitance effect of the IO pin (driving current, packaging, etc.). Touch key channels TK3/PA7 and TK4/PA0/CS1 have slightly smaller touch key counts than other pins.
3. In ByPass mode, the Touch START (write "0x10" into TCC register) command must be executed at a system frequency of 250KHz (IHRC/64). The LDO mode does not have this limitation.

6. IO Registers

6.1. ACC Status Flag Register (*flag*), IO address = 0x00

Bit	Reset	R/W	Description
7 - 4	-	-	Reserved. These four bits are "1" when read.
3	-	R/W	OV (Overflow). This bit is set whenever the sign operation is overflow.
2	-	R/W	AC (Auxiliary Carry). There are two conditions to set this bit, the first one is carry out of low nibble in addition operation, and the other one is borrow from the high nibble into low nibble in subtraction operation.
1	-	R/W	C (Carry). There are two conditions to set this bit, the first one is carry out in addition operation, and the other one is borrow in subtraction operation. Carry is also affected by shift with carry instruction.
0	-	R/W	Z (Zero). This bit will be set when the result of arithmetic or logic operation is zero; Otherwise, it is cleared.

6.2. Stack Pointer Register (*sp*), IO address = 0x02

Bit	Reset	R/W	Description
7 - 0	-	R/W	Stack Pointer Register. Read out the current stack pointer, or write to change the stack pointer. Please notice that bit 0 should be kept 0 due to program counter is 16 bits.

6.3. Clock Mode Register (*clkmd*), IO address = 0x03

Bit	Reset	R/W	Description		
7 - 5	111	R/W	System clock selection:		
			Type 0, clkmd[3]=0	Type 1, clkmd[3]=1	
			<table style="width: 100%; border-collapse: collapse;"> <tr> <td style="width: 50%; vertical-align: top;"> 000: IHRC/4 001: IHRC/2 01x: reserved 100: reserved 101: reserved 110: ILRC/4 111: ILRC (default) </td> <td style="width: 50%; vertical-align: top;"> 000: IHRC/16 001: IHRC/8 010: ILRC/16 (ICE doesn't support) 011: IHRC/32 100: IHRC/64 110: reserved 1x1: reserved. </td> </tr> </table>	000: IHRC/4 001: IHRC/2 01x: reserved 100: reserved 101: reserved 110: ILRC/4 111: ILRC (default)	000: IHRC/16 001: IHRC/8 010: ILRC/16 (ICE doesn't support) 011: IHRC/32 100: IHRC/64 110: reserved 1x1: reserved.
000: IHRC/4 001: IHRC/2 01x: reserved 100: reserved 101: reserved 110: ILRC/4 111: ILRC (default)	000: IHRC/16 001: IHRC/8 010: ILRC/16 (ICE doesn't support) 011: IHRC/32 100: IHRC/64 110: reserved 1x1: reserved.				
4	0	R/W	IHRC oscillator Enable. 0 / 1: disable / enable		
3	0	R/W	Clock Type Select. This bit is used to select the clock type in bit [7:5]. 0 / 1: Type 0 / Type 1		
2	1	R/W	ILRC Enable. 0 / 1: disable / enable If ILRC is disabled, watchdog timer is also disabled.		
1	1	R/W	Watch Dog Enable. 0 / 1: disable / enable		
0	0	R/W	Pin PA5/PRSTB function. 0 / 1: PA5 / PRSTB		

6.4. Interrupt Enable Register (*inten*), IO address = 0x04

Bit	Reset	R/W	Description
7	0	R/W	Enable interrupt from Timer3. 0 / 1: disable / enable
6	0	R/W	Enable interrupt from Timer2. 0 / 1: disable / enable
5	0	R/W	Enable interrupt from Touch Key TK_OV. 0 / 1: disable / enable
4	0	R/W	Enable interrupt from comparator. 0 / 1: disable / enable
3	0	R/W	Enable interrupt from Touch Key TK_END. 0 / 1: disable / enable
2	0	R/W	Enable interrupt from Timer16 overflow. 0 / 1: disable / enable
1	-	-	Reserved.
0	0	R/W	Enable interrupt from PA0/PA5. 0 / 1: disable / enable

6.5. Interrupt Request Register (*intrq*), IO address = 0x05

Bit	Reset	R/W	Description
7	-	R/W	Interrupt Request from Timer3, this bit is set by hardware and cleared by software. 0 / 1: No request / Request
6	-	R/W	Interrupt Request from Timer2, this bit is set by hardware and cleared by software. 0 / 1: No request / Request
5	-	R/W	Interrupt Request from Touch Key TK_OV, this bit is set by hardware and cleared by software. 0 / 1: No request / Request
4	-	R/W	Interrupt Request from comparator, this bit is set by hardware and cleared by software. 0 / 1: No request / Request
3	-	R/W	Interrupt Request from Touch Key TK_END, this bit is set by hardware and cleared by software. 0 / 1: No request / Request
2	-	R/W	Interrupt Request from Timer16, this bit is set by hardware and cleared by software. 0 / 1: No request / Request
1	-	-	Reserved.
0	-	R/W	Interrupt Request from pin PA0/PA5, this bit is set by hardware and cleared by software. 0 / 1: No request / Request

6.6. Timer 16 mode Register (*t16m*), IO address = 0x06

Bit	Reset	R/W	Description
7 - 5	000	R/W	Timer Clock source selection 000: Timer 16 is disabled 001: CLK (system clock) 010: reserved 011: PA4 falling edge (from external pin) 100: IHRC 101: reserved 110: ILRC 111: PA0 falling edge (from external pin)
4 - 3	00	R/W	Internal clock divider. 00: ÷1 01: ÷4 10: ÷16 11: ÷64
2 - 0	000	R/W	Interrupt source selection. Interrupt event happens when selected bit is changed. 0 : bit 8 of Timer16 1 : bit 9 of Timer16 2 : bit 10 of Timer16 3 : bit 11 of Timer16 4 : bit 12 of Timer16 5 : bit 13 of Timer16 6 : bit 14 of Timer16 7 : bit 15 of Timer16

6.7. Interrupt Edge Select Register (*integs*), IO address = 0x0c

Bit	Reset	R/W	Description
7 - 6	00	WO	GPC edge selection. 00 : both rising edge and falling edge to trigger interrupt 01 : rising edge to trigger interrupt 10 : falling edge to trigger interrupt 11 : reserved.
5	-	-	Reserved. Please keep 0.
4	0	WO	Timer16 edge selection. 0 : rising edge to trigger interrupt 1 : falling edge to trigger interrupt
3 - 2	-	-	Reserved. Please keep 0.
1 - 0	00	WO	PA0 / PA5 edge selection. 00 : both rising edge and falling edge to trigger interrupt 01 : rising edge to trigger interrupt 10 : falling edge to trigger interrupt 11 : reserved.

6.8. Port A Digital Input Enable Register (*padier*), IO address = 0x0d

Bit	Reset	R/W	Description
7 - 6	11	WO	Enable PA7~PA6 digital input and wake up event. 1 / 0 : enable / disable These bits can be set to low to disable wake up from PA7~PA6 toggling.
5	1	WO	Enable PA5 digital input, wake up event and interrupt request. 1 / 0 : enable / disable This bit can be set to low to disable wake up from PA5 toggling and interrupt request from this pin.
4 - 3	11	WO	Enable PA4~PA3 digital input and wake up event. 1 / 0 : enable / disable These bits can be set to low to disable wake up from PA4~PA3 toggling.
2 - 1	-	-	Reserved. (Please keep 00 for future compatibility)
0	1	WO	Enable PA0 digital input, wake up event and interrupt request. 1 / 0 : enable / disable This bit can be set to low to disable wake up from PA0 toggling and interrupt request from this pin.

6.9. Port A Data Registers (*pa*), IO address = 0x10

Bit	Reset	R/W	Description
7 - 0	0x00	R/W	Data registers for Port A.

6.10. Port A Control Registers (*pac*), IO address = 0x11

Bit	Reset	R/W	Description
7 - 0	0x00	R/W	Port A control registers. This register is used to define input mode or output mode for each corresponding pin of port A. 0 / 1: input / output.

6.11. Port A Pull-High Registers (*paph*), IO address = 0x12

Bit	Reset	R/W	Description
7 - 0	0x00	R/W	Port A pull-high registers. This register is used to enable the internal pull-high device on each corresponding pin of port A. 0 / 1 : disable / enable

6.12. Port A Pull-Low Registers (*papl*), IO address = 0x13

Bit	Reset	R/W	Description
7 - 0	0x00	R/W	Port A pull-low registers. This register is used to enable the internal pull-low device on each corresponding pin of port A. 0 / 1 : disable / enable

6.13. Miscellaneous Register (*misc*), IO address = 0x1b

Bit	Reset	R/W	Description
7 - 6	-	-	Reserved. (Keep 0 for future compatibility)
5	0	WO	Enable fast Wake-up. Fast wake-up is NOT supported when EOSC is enabled. 0: Normal wake-up. The wake-up time is 3000 ILRC clocks (Not for fast boot-up). 1: Fast wake-up. The wake-up time is 45 ILRC clocks.
4 - 3	-	-	Reserved. (Keep 0 for future compatibility)
2	0	WO	Disable LVR function. 0 / 1: Enable / Disable
1 - 0	00	WO	Watch dog time out period. 00: 8k ILRC clock period 01: 16k ILRC clock period 10: 64k ILRC clock period 11: 256k ILRC clock period

6.14. Comparator Control Register (*gpcc*), IO address = 0x1a

Bit	Reset	R/W	Description
7	0	R/W	Enable comparator. 0 / 1 : disable / enable When this bit is set to enable, please also set the corresponding analog input pins to be digital disable to prevent IO leakage.
6	-	RO	Comparator result of comparator. 0: plus input < minus input 1: plus input > minus input
5	0	R/W	Select whether the comparator result output will be sampled by TM2_CLK? 0: result output NOT sampled by TM2_CLK 1: result output sampled by TM2_CLK
4	0	R/W	Inverse the polarity of result output of comparator. 0: polarity is NOT inverted. 1: polarity is inverted.
3 - 1	000	R/W	Selection the minus input (-) of comparator. 000 : PA3 001 : PA4 010 : Internal 1.20 volt bandgap reference voltage 011 : V _{internal R} 100 : PA6 101 : reserved 11X: reserved
0	0	R/W	Selection the plus input (+) of comparator. 0 : V _{internal R} 1 : PA4

6.15. Comparator Selection Register (*gpcs*), IO address = 0x1e

Bit	Reset	R/W	Description
7	0	WO	Comparator output enable (to PA0). 0 / 1 : disable / enable
6	0	WO	Wakeup by comparator enable. (The comparator wakeup effectively when gpcc.6 electrical level changed) 0 / 1 : disable / enable
5	0	WO	Selection of high range of comparator.
4	0	WO	Selection of low range of comparator.
3 - 0	0000	WO	Selection the voltage level of comparator. 0000 (lowest) ~ 1111 (highest)

6.16. Timer2 Control Register (*tm2c*), IO address = 0x1c

Bit	Reset	R/W	Description
7 - 4	0000	R/W	Timer2 clock selection. 0000 : disable 0001 : system clock 0010 : internal high RC oscillator (IHRC) 0011 : reserved 0100 : ILRC 0101 : comparator output 011x : reserved 1000 : PA0 (rising edge) 1001 : ~PA0 (falling edge) 101x : reserved 1100 : PA4 (rising edge) 1101 : ~PA4 (falling edge)
3 - 2	00	R/W	Timer2 output selection. 00 : disable 01 : reserved 10 : PA3 11 : PA4
1	0	R/W	Reserved
0	0	R/W	Enable to inverse the polarity of Timer2 output. 0 / 1: disable / enable

6.17. Timer2 Counter Register (*tm2ct*), IO address = 0x1d

Bit	Reset	R/W	Description
7 - 0	0x00	RO	Bit [7:0] of Timer2 counter register.

Note: Timer2 is designed for Period mode, so do not read tm2ct register.

6.18. Timer2 Scalar Register (*tm2s*), IO address = 0x17

Bit	Reset	R/W	Description
7	0	WO	reserved
6 - 5	00	WO	Timer2 clock pre-scalar. 00 : ÷ 1 01 : ÷ 4 10 : ÷ 16 11 : ÷ 64
4 - 0	00000	WO	Timer2 clock scalar.

6.19. Timer2 Bound Register (*tm2b*), IO address = 0x09

Bit	Reset	R/W	Description
7 - 0	0x00	WO	Timer2 bound register.

6.20. Timer3 Control Register (*tm3c*), IO address = 0x32

Bit	Reset	R/W	Description
7	-	-	Reserved.
6 - 4	000	R/W	Timer3 clock selection. 000 : disable 001 : system clock 010 : internal high RC oscillator (IHRC) 011 : reserved 100 : ILRC 101 : comparator output 101 : NILRC 111 : reserved.
3 - 1	-	-	reserved
0	0	R/W	NILRC Enable. 0 / 1: disable / enable

6.21. Timer3 Counter Register (*tm3ct*), IO address = 0x33

Bit	Reset	R/W	Description
7 - 0	0x00	R/W	Bit [7:0] of Timer3 counter register.

6.22. Timer3 Scalar Register (*tm3s*), IO address = 0x34

Bit	Reset	R/W	Description
7	0	WO	reserved
6 - 5	00	WO	Timer3 clock pre-scalar. 00 : ÷ 1 01 : ÷ 4 10 : ÷ 16 11 : ÷ 64
4 - 2		WO	reserved
1 - 0	00	WO	Timer3 clock scalar. 00 : ÷ 1 01 : ÷ 2 10 : reserved 11 : ÷ 4

6.23. Timer3 Bound Register (*tm3b*), IO address = 0x35

Bit	Reset	R/W	Description
7 - 0	0x00	WO	Timer3 bound register.

6.24. Touch Selection Register (*ts*), IO address = 0x37

Bit	Reset	R/W	Description
7	-	-	reserved
6 - 5	-	R/W	Touch clock selection (TK_CLK) 00: IHRC/16 01: IHRC/2 10: IHRC/4 11: IHRC/8
4 - 2	011	R/W	Touch VREF selection (TP: Touch Power, the default is LDO 2V) 000: 0.8 * TP 001: 0.7 * TP 010: 0.6 * TP 011: 0.5 * TP 100: 0.4 * TP 101: 0.3 * TP 110: 0.2 * TP 111: reserved
1 - 0	-	R/W	Select the discharge time before starting the touch function (TK_DISCHG) 00: reserved 01: 32 * CLK 10: 64 * CLK 11: 128 * CLK

Note: LDO mode TP defaults to LDO 2V, ByPass mode TP is IC_VDD.

6.25. Touch Charge Control Register (*tcc*), IO address = 0x38

Bit	Reset	R/W	Description		
7	0	-	OV Enable 0/1: disable/enable After OV is enabled, the counter will start counting from zero automatically when it overflows.		
6 - 4	-	WO	Touch control and status		
			Data	Command (W)	Status (R)
			000	TK_STOP (Touch module power down)	Ready / End
			001	TK_RUN (Touch START)	Running
			011	Discharge (Discharge CS capacitor)	Discharging
			Others	Reserved	Reserved
3 - 0	-	-	Reserved		

Note: In ByPass mode, the Touch START (write "0x10" into TCC register) command must be executed at a system frequency of 250KHz (IHRC/64). The LDO mode does not have this limitation.

6.26. Touch Key Enable 1 Register (*tke1*), IO address = 0x3b

Bit	Reset	R/W	Description
7	0	R/W	Enable PA0/TK4. 0/1: disable/enable
6	0	R/W	Enable PA4/TK3. 0/1: disable/enable
5	0	R/W	Enable PA3/TK2. 0/1: disable/enable
4	-	-	Reserved
3	0	R/W	Enable PA6/TK1. 0/1: disable/enable
2	0	R/W	Enable PA5/TK0. 0/1: disable/enable
1 - 0	-	-	Reserved

6.27. Touch Key Charge Counter High Register (*tkch*), IO address = 0x3e

Bit	Reset	R/W	Description
7 - 4	-	-	Reserved
3 - 0	-	RO	tkc [11:8] of touch key charge counter.

6.28. Touch Key Charge Counter Low Register (*tkcl*), IO address = 0x3f

Bit	Reset	R/W	Description
7 - 0	-	RO	tkc [7:0] of touch key charge counter.

6.29. External Power Operate Register (*eoscr*), IO address = 0x0a

Bit	Reset	R/W	Description
7 - 4	-	-	Reserved
3	0	WO	LDO output voltage option. 0/1: 2.4V/2V
2	0	WO	Touch module power option. 0/1 : VDD/LDO
1	-	-	Reserved
0	0	WO	BG LVD power. 0/1 : On/Off

Note: Set EOSCR[3:2] to select touch module power (TP).

6.30. Touch parameter setting Register (*tps*), IO address = 0x3C

Bit	Reset	R/W	Description
7 - 0	0x00	R/W	Reserved, keep Default value or 0x00

Note : TPS = 0x00.

6.31. Touch parameter setting Register (*tps2*), IO address = 0x3D

Bit	Reset	R/W	Description
7 - 6	-	R/W	Touch module type: (For specific settings of different power supplies, please refer to Section 5.1.4) 00: Type A (ByPass mode, CS capacitor connect to VDD) 01: Type B (LDO mode, CS capacitor connect to GND)
5 - 2	0000	R/W	Reserved, keep 0
1 - 0	00	R/W	01: VREF always on through entire process. Suggestion: keep 0x01

Case:

// Bypass Mode:

\$ EOSCR TK_VDD;

\$ TPS2 Type A, Always On //ByPass, Type A, CS capacitor connect to VDD

// LDO Mode

\$ EOSCR TK 2V,TK_LDO

\$ TPS2 Type B, Always_On //LDO, Type B, CS capacitor connect to GND

7. Instructions

Symbol	Description
ACC	Accumulator (Abbreviation of accumulator)
a	Accumulator (Symbol of accumulator in program)
sp	Stack pointer
flag	ACC status flag register
I	Immediate data
&	Logical AND
	Logical OR
←	Movement
^	Exclusive logic OR
+	Add
-	Subtraction
~	NOT (logical complement, 1's complement)
\bar{T}	NEG (2's complement)
OV	Overflow (The operational result is out of range in signed 2's complement number system)
Z	Zero (If the result of ALU operation is zero, this bit is set to 1)
C	Carry (The operational result is to have carry out for addition or to borrow carry for subtraction in unsigned number system)
AC	Auxiliary Carry (If there is a carry out from low nibble after the result of ALU operation, this bit is set to 1)
M.n	Only addressed in 0~0x3F (0~63) is allowed

7.1. Data Transfer Instructions

<i>mov</i> a, l	<p>Move immediate data into ACC. Example: <i>mov</i> a, 0x0f; Result: a ← 0fh; Affected flags: 『N』 Z 『N』 C 『N』 AC 『N』 OV</p>
<i>mov</i> M, a	<p>Move data from ACC into memory Example: <i>mov</i> MEM, a; Result: MEM ← a Affected flags: 『N』 Z 『N』 C 『N』 AC 『N』 OV</p>
<i>mov</i> a, M	<p>Move data from memory into ACC Example: <i>mov</i> a, MEM ; Result: a ← MEM; Flag Z is set when MEM is zero. Affected flags: 『Y』 Z 『N』 C 『N』 AC 『N』 OV</p>
<i>mov</i> a, IO	<p>Move data from IO into ACC Example: <i>mov</i> a, pa ; Result: a ← pa; Flag Z is set when pa is zero. Affected flags: 『Y』 Z 『N』 C 『N』 AC 『N』 OV</p>
<i>mov</i> IO, a	<p>Move data from ACC into IO Example: <i>mov</i> pa, a; Result: pa ← a Affected flags: 『N』 Z 『N』 C 『N』 AC 『N』 OV</p>
<i>ldt16</i> word	<p>Move 16-bit counting values in Timer16 to memory in word. Example: <i>ldt16</i> word; Result: word ← 16-bit timer Affected flags: 『N』 Z 『N』 C 『N』 AC 『N』 OV</p> <p>Application Example:</p> <pre> ----- word T16val ; // declare a RAM word ... clear lb@ T16val ; // clear T16val (LSB) clear hb@ T16val ; // clear T16val (MSB) stt16 T16val ; // initial T16 with 0 ... set1 t16m.5 ; // enable Timer16 ... set0 t16m.5 ; // disable Timer 16 ldt16 T16val ; // save the T16 counting value to T16val ----- </pre>

<i>stt16</i> word	<p>Store 16-bit data from memory in word to Timer16.</p> <p>Example: <i>stt16</i> word;</p> <p>Result: 16-bit timer ←word</p> <p>Affected flags: 『N』 Z 『N』 C 『N』 AC 『N』 OV</p> <p>Application Example:</p> <hr style="border-top: 1px dashed black;"/> <pre style="margin: 0;">word T16val ; // declare a RAM word ... mov a, 0x34 ; mov lb@ T16val , a ; // move 0x34 to T16val (LSB) mov a, 0x12 ; mov hb@ T16val , a ; // move 0x12 to T16val (MSB) stt16 T16val ; // initial T16 with 0x1234 ... </pre> <hr style="border-top: 1px dashed black;"/>
<i>idxm</i> a, index	<p>Move data from specified memory to ACC by indirect method. It needs 2T to execute this instruction.</p> <p>Example: <i>idxm</i> a, index;</p> <p>Result: a ← [index], where index is declared by word.</p> <p>Affected flags: 『N』 Z 『N』 C 『N』 AC 『N』 OV</p> <p>Application Example:</p> <hr style="border-top: 1px dashed black;"/> <pre style="margin: 0;">word RAMIndex ; // declare a RAM pointer ... mov a, 0x5B ; // assign pointer to an address (LSB) mov lb@RAMIndex, a ; // save pointer to RAM (LSB) mov a, 0x00 ; // assign 0x00 to an address (MSB), should be 0 mov hb@RAMIndex, a ; // save pointer to RAM (MSB) ... idxm a, RAMIndex ; // move memory data in address 0x5B to ACC </pre> <hr style="border-top: 1px dashed black;"/>
<i>ldxm</i> index, a	<p>Move data from ACC to specified memory by indirect method. It needs 2T to execute this instruction.</p> <p>Example: <i>ldxm</i> index, a;</p> <p>Result: [index] ← a; where index is declared by word.</p> <p>Affected flags: 『N』 Z 『N』 C 『N』 AC 『N』 OV</p> <p>Application Example:</p> <hr style="border-top: 1px dashed black;"/> <pre style="margin: 0;">word RAMIndex ; // declare a RAM pointer ... mov a, 0x5B ; // assign pointer to an address (LSB) mov lb@RAMIndex, a ; // save pointer to RAM (LSB) mov a, 0x00 ; // assign 0x00 to an address (MSB), should be 0 mov hb@RAMIndex, a ; // save pointer to RAM (MSB) ... mov a, 0xA5 ; ldxm RAMIndex, a ; // move 0xA5 to memory in address 0x5B </pre> <hr style="border-top: 1px dashed black;"/>

<i>xch</i> <i>M</i>	<p>Exchange data between ACC and memory</p> <p>Example: <code>xch MEM ;</code></p> <p>Result: $MEM \leftarrow a, a \leftarrow MEM$</p> <p>Affected flags: 『N』 Z 『N』 C 『N』 AC 『N』 OV</p>
<i>pushaf</i>	<p>Move the ACC and flag register to memory that address specified in the stack pointer.</p> <p>Example: <code>pushaf;</code></p> <p>Result: $[sp] \leftarrow \{flag, ACC\};$ $sp \leftarrow sp + 2 ;$</p> <p>Affected flags: 『N』 Z 『N』 C 『N』 AC 『N』 OV</p> <p>Application Example:</p> <hr style="border-top: 1px dashed black;"/> <pre>.romadr 0x10 ; // ISR entry address pushaf ; // put ACC and flag into stack memory ... // ISR program ... // ISR program popaf ; // restore ACC and flag from stack memory reti ;</pre> <hr style="border-top: 1px dashed black;"/>
<i>popaf</i>	<p>Restore ACC and flag from the memory which address is specified in the stack pointer.</p> <p>Example: <code>popaf;</code></p> <p>Result: $sp \leftarrow sp - 2 ;$ $\{Flag, ACC\} \leftarrow [sp] ;$</p> <p>Affected flags: 『Y』 Z 『Y』 C 『Y』 AC 『Y』 OV</p>

7.2. Arithmetic Operation Instructions

<i>add</i> <i>a, I</i>	<p>Add immediate data with ACC, then put result into ACC</p> <p>Example: <code>add a, 0x0f ;</code></p> <p>Result: $a \leftarrow a + 0fh$</p> <p>Affected flags: 『Y』 Z 『Y』 C 『Y』 AC 『Y』 OV</p>
<i>add</i> <i>a, M</i>	<p>Add data in memory with ACC, then put result into ACC</p> <p>Example: <code>add a, MEM ;</code></p> <p>Result: $a \leftarrow a + MEM$</p> <p>Affected flags: 『Y』 Z 『Y』 C 『Y』 AC 『Y』 OV</p>
<i>add</i> <i>M, a</i>	<p>Add data in memory with ACC, then put result into memory</p> <p>Example: <code>add MEM, a;</code></p> <p>Result: $MEM \leftarrow a + MEM$</p> <p>Affected flags: 『Y』 Z 『Y』 C 『Y』 AC 『Y』 OV</p>
<i>addc</i> <i>a, M</i>	<p>Add data in memory with ACC and carry bit, then put result into ACC</p> <p>Example: <code>addc a, MEM ;</code></p> <p>Result: $a \leftarrow a + MEM + C$</p> <p>Affected flags: 『Y』 Z 『Y』 C 『Y』 AC 『Y』 OV</p>
<i>addc</i> <i>M, a</i>	<p>Add data in memory with ACC and carry bit, then put result into memory</p> <p>Example: <code>addc MEM, a ;</code></p> <p>Result: $MEM \leftarrow a + MEM + C$</p> <p>Affected flags: 『Y』 Z 『Y』 C 『Y』 AC 『Y』 OV</p>
<i>addc</i> <i>a</i>	<p>Add carry with ACC, then put result into ACC</p>

	<p>Example: <code>addc a;</code> Result: $a \leftarrow a + C$ Affected flags: 『Y』 Z 『Y』 C 『Y』 AC 『Y』 OV</p>
<code>addc M</code>	<p>Add carry with memory, then put result into memory Example: <code>addc MEM;</code> Result: $MEM \leftarrow MEM + C$ Affected flags: 『Y』 Z 『Y』 C 『Y』 AC 『Y』 OV</p>
<code>nadd a, M</code>	<p>Add negative logic (2's complement) of ACC with memory Example: <code>nadd a, MEM;</code> Result: $a \leftarrow \overline{a} + MEM$ Affected flags: 『Y』 Z 『Y』 C 『Y』 AC 『Y』 OV</p>
<code>nadd M, a</code>	<p>Add negative logic (2's complement) of memory with ACC Example: <code>nadd MEM, a;</code> Result: $MEM \leftarrow \overline{MEM} + a$ Affected flags: 『Y』 Z 『Y』 C 『Y』 AC 『Y』 OV</p>
<code>sub a, I</code>	<p>Subtraction immediate data from ACC, then put result into ACC. Example: <code>sub a, 0x0f;</code> Result: $a \leftarrow a - 0fh$ ($a + [2's \text{ complement of } 0fh]$) Affected flags: 『Y』 Z 『Y』 C 『Y』 AC 『Y』 OV</p>
<code>sub a, M</code>	<p>Subtraction data in memory from ACC, then put result into ACC Example: <code>sub a, MEM;</code> Result: $a \leftarrow a - MEM$ ($a + [2's \text{ complement of } M]$) Affected flags: 『Y』 Z 『Y』 C 『Y』 AC 『Y』 OV</p>
<code>sub M, a</code>	<p>Subtraction data in ACC from memory, then put result into memory Example: <code>sub MEM, a;</code> Result: $MEM \leftarrow MEM - a$ ($MEM + [2's \text{ complement of } a]$) Affected flags: 『Y』 Z 『Y』 C 『Y』 AC 『Y』 OV</p>
<code>subc a, M</code>	<p>Subtraction data in memory and carry from ACC, then put result into ACC Example: <code>subc a, MEM;</code> Result: $a \leftarrow a - MEM - C$ Affected flags: 『Y』 Z 『Y』 C 『Y』 AC 『Y』 OV</p>
<code>subc M, a</code>	<p>Subtraction ACC and carry bit from memory, then put result into memory Example: <code>subc MEM, a;</code> Result: $MEM \leftarrow MEM - a - C$ Affected flags: 『Y』 Z 『Y』 C 『Y』 AC 『Y』 OV</p>
<code>subc a</code>	<p>Subtraction carry from ACC, then put result into ACC Example: <code>subc a;</code> Result: $a \leftarrow a - C$ Affected flags: 『Y』 Z 『Y』 C 『Y』 AC 『Y』 OV</p>
<code>subc M</code>	<p>Subtraction carry from the content of memory, then put result into memory Example: <code>subc MEM;</code> Result: $MEM \leftarrow MEM - C$ Affected flags: 『Y』 Z 『Y』 C 『Y』 AC 『Y』 OV</p>
<code>inc M</code>	<p>Increment the content of memory Example: <code>inc MEM;</code> Result: $MEM \leftarrow MEM + 1$ Affected flags: 『Y』 Z 『Y』 C 『Y』 AC 『Y』 OV</p>

<i>dec</i> M	Decrement the content of memory Example: <i>dec</i> MEM; Result: MEM ← MEM - 1 Affected flags: 『Y』 Z 『Y』 C 『Y』 AC 『Y』 OV
<i>clear</i> M	Clear the content of memory Example: <i>clear</i> MEM ; Result: MEM ← 0 Affected flags: 『N』 Z 『N』 C 『N』 AC 『N』 OV

7.3. Shift Operation Instructions

<i>sr</i> a	Shift right of ACC, shift 0 to bit 7 Example: <i>sr</i> a ; Result: a (0,b7,b6,b5,b4,b3,b2,b1) ← a (b7,b6,b5,b4,b3,b2,b1,b0), C ← a(b0) Affected flags: 『N』 Z 『Y』 C 『N』 AC 『N』 OV
<i>src</i> a	Shift right of ACC with carry bit 7 to flag Example: <i>src</i> a ; Result: a (c,b7,b6,b5,b4,b3,b2,b1) ← a (b7,b6,b5,b4,b3,b2,b1,b0), C ← a(b0) Affected flags: 『N』 Z 『Y』 C 『N』 AC 『N』 OV
<i>sr</i> M	Shift right the content of memory, shift 0 to bit 7 Example: <i>sr</i> MEM ; Result: MEM(0,b7,b6,b5,b4,b3,b2,b1) ← MEM(b7,b6,b5,b4,b3,b2,b1,b0), C ← MEM(b0) Affected flags: 『N』 Z 『Y』 C 『N』 AC 『N』 OV
<i>src</i> M	Shift right of memory with carry bit 7 to flag Example: <i>src</i> MEM ; Result: MEM(c,b7,b6,b5,b4,b3,b2,b1) ← MEM (b7,b6,b5,b4,b3,b2,b1,b0), C ← MEM(b0) Affected flags: 『N』 Z 『Y』 C 『N』 AC 『N』 OV
<i>sl</i> a	Shift left of ACC shift 0 to bit 0 Example: <i>sl</i> a ; Result: a (b6,b5,b4,b3,b2,b1,b0,0) ← a (b7,b6,b5,b4,b3,b2,b1,b0), C ← a (b7) Affected flags: 『N』 Z 『Y』 C 『N』 AC 『N』 OV
<i>slc</i> a	Shift left of ACC with carry bit 0 to flag Example: <i>slc</i> a ; Result: a (b6,b5,b4,b3,b2,b1,b0,c) ← a (b7,b6,b5,b4,b3,b2,b1,b0), C ← a(b7) Affected flags: 『N』 Z 『Y』 C 『N』 AC 『N』 OV
<i>sl</i> M	Shift left of memory, shift 0 to bit 0 Example: <i>sl</i> MEM ; Result: MEM (b6,b5,b4,b3,b2,b1,b0,0) ← MEM (b7,b6,b5,b4,b3,b2,b1,b0), C ← MEM(b7) Affected flags: 『N』 Z 『Y』 C 『N』 AC 『N』 OV
<i>slc</i> M	Shift left of memory with carry bit 0 to flag Example: <i>slc</i> MEM ; Result: MEM (b6,b5,b4,b3,b2,b1,b0,C) ← MEM (b7,b6,b5,b4,b3,b2,b1,b0), C ← MEM (b7) Affected flags: 『N』 Z 『Y』 C 『N』 AC 『N』 OV
<i>swap</i> a	Swap the high nibble and low nibble of ACC Example: <i>swap</i> a ; Result: a (b3,b2,b1,b0,b7,b6,b5,b4) ← a (b7,b6,b5,b4,b3,b2,b1,b0) Affected flags: 『N』 Z 『N』 C 『N』 AC 『N』 OV

7.4. Logic Operation Instructions

<i>and</i> a, I	<p>Perform logic AND on ACC and immediate data, then put result into ACC</p> <p>Example: <i>and</i> a, 0x0f ;</p> <p>Result: $a \leftarrow a \& 0fh$</p> <p>Affected flags: 『Y』 Z 『N』 C 『N』 AC 『N』 OV</p>
<i>and</i> a, M	<p>Perform logic AND on ACC and memory, then put result into ACC</p> <p>Example: <i>and</i> a, RAM10 ;</p> <p>Result: $a \leftarrow a \& RAM10$</p> <p>Affected flags: 『Y』 Z 『N』 C 『N』 AC 『N』 OV</p>
<i>and</i> M, a	<p>Perform logic AND on ACC and memory, then put result into memory</p> <p>Example: <i>and</i> MEM, a ;</p> <p>Result: $MEM \leftarrow a \& MEM$</p> <p>Affected flags: 『Y』 Z 『N』 C 『N』 AC 『N』 OV</p>
<i>or</i> a, I	<p>Perform logic OR on ACC and immediate data, then put result into ACC</p> <p>Example: <i>or</i> a, 0x0f ;</p> <p>Result: $a \leftarrow a 0fh$</p> <p>Affected flags: 『Y』 Z 『N』 C 『N』 AC 『N』 OV</p>
<i>or</i> a, M	<p>Perform logic OR on ACC and memory, then put result into ACC</p> <p>Example: <i>or</i> a, MEM ;</p> <p>Result: $a \leftarrow a MEM$</p> <p>Affected flags: 『Y』 Z 『N』 C 『N』 AC 『N』 OV</p>
<i>or</i> M, a	<p>Perform logic OR on ACC and memory, then put result into memory</p> <p>Example: <i>or</i> MEM, a ;</p> <p>Result: $MEM \leftarrow a MEM$</p> <p>Affected flags: 『Y』 Z 『N』 C 『N』 AC 『N』 OV</p>
<i>xor</i> a, I	<p>Perform logic XOR on ACC and immediate data, then put result into ACC</p> <p>Example: <i>xor</i> a, 0x0f ;</p> <p>Result: $a \leftarrow a \wedge 0fh$</p> <p>Affected flags: 『Y』 Z 『N』 C 『N』 AC 『N』 OV</p>
<i>xor</i> IO, a	<p>Perform logic XOR on ACC and IO register, then put result into IO register</p> <p>Example: <i>xor</i> pa, a ;</p> <p>Result: $pa \leftarrow a \wedge pa$; // pa is the data register of port A</p> <p>Affected flags: 『N』 Z 『N』 C 『N』 AC 『N』 OV</p>
<i>xor</i> a, M	<p>Perform logic XOR on ACC and memory, then put result into ACC</p> <p>Example: <i>xor</i> a, MEM ;</p> <p>Result: $a \leftarrow a \wedge RAM10$</p> <p>Affected flags: 『Y』 Z 『N』 C 『N』 AC 『N』 OV</p>
<i>xor</i> M, a	<p>Perform logic XOR on ACC and memory, then put result into memory</p> <p>Example: <i>xor</i> MEM, a ;</p> <p>Result: $MEM \leftarrow a \wedge MEM$</p> <p>Affected flags: 『Y』 Z 『N』 C 『N』 AC 『N』 OV</p>

<i>not</i> a	<p>Perform 1's complement (logical complement) of ACC</p> <p>Example: <i>not</i> a ;</p> <p>Result: a ← $\sim a$</p> <p>Affected flags: 『Y』 Z 『N』 C 『N』 AC 『N』 OV</p> <p>Application Example:</p> <hr style="border-top: 1px dashed black;"/> <pre style="margin-left: 20px;"> mov a, 0x38 ; // ACC=0X38 not a ; // ACC=0XC7 </pre> <hr style="border-top: 1px dashed black;"/>
<i>not</i> M	<p>Perform 1's complement (logical complement) of memory</p> <p>Example: <i>not</i> MEM ;</p> <p>Result: MEM ← $\sim \text{MEM}$</p> <p>Affected flags: 『Y』 Z 『N』 C 『N』 AC 『N』 OV</p> <p>Application Example:</p> <hr style="border-top: 1px dashed black;"/> <pre style="margin-left: 20px;"> mov a, 0x38 ; mov mem, a ; // mem = 0x38 not mem ; // mem = 0xC7 </pre> <hr style="border-top: 1px dashed black;"/>
<i>neg</i> a	<p>Perform 2's complement of ACC</p> <p>Example: <i>neg</i> a ;</p> <p>Result: a ← \overline{a}</p> <p>Affected flags: 『Y』 Z 『N』 C 『N』 AC 『N』 OV</p> <p>Application Example:</p> <hr style="border-top: 1px dashed black;"/> <pre style="margin-left: 20px;"> mov a, 0x38 ; // ACC=0X38 neg a ; // ACC=0XC8 </pre> <hr style="border-top: 1px dashed black;"/>
<i>neg</i> M	<p>Perform 2's complement of memory</p> <p>Example: <i>neg</i> MEM ;</p> <p>Result: MEM ← $\overline{\text{MEM}}$</p> <p>Affected flags: 『Y』 Z 『N』 C 『N』 AC 『N』 OV</p> <p>Application Example:</p> <hr style="border-top: 1px dashed black;"/> <pre style="margin-left: 20px;"> mov a, 0x38 ; mov mem, a ; // mem = 0x38 not mem ; // mem = 0xC8 </pre> <hr style="border-top: 1px dashed black;"/>

<i>comp</i> a, M	<p>Compare ACC with the content of memory</p> <p>Example: <i>comp</i> a, MEM;</p> <p>Result: Flag will be changed by regarding as (a - MEM)</p> <p>Affected flags: 『Y』 Z 『Y』 C 『Y』 AC 『Y』 OV</p> <p>Application Example:</p> <hr style="border-top: 1px dashed black;"/> <pre style="margin-left: 40px;"> mov a, 0x38 ; mov mem, a ; comp a, mem ; // Z flag is set as 1 mov a, 0x42 ; mov mem, a ; mov a, 0x38 ; comp a, mem ; // C flag is set as 1 </pre> <hr style="border-top: 1px dashed black;"/>
<i>comp</i> M, a	<p>Compare ACC with the content of memory</p> <p>Example: <i>comp</i> MEM, a;</p> <p>Result: Flag will be changed by regarding as (MEM - a)</p> <p>Affected flags: 『Y』 Z 『Y』 C 『Y』 AC 『Y』 OV</p>

7.5. Bit Operation Instructions

<i>set0</i> IO.n	<p>Set bit n of IO port to low</p> <p>Example: <i>set0</i> pa.5 ;</p> <p>Result: set bit 5 of port A to low</p> <p>Affected flags: 『N』 Z 『N』 C 『N』 AC 『N』 OV</p>
<i>set1</i> IO.n	<p>Set bit n of IO port to high</p> <p>Example: <i>set1</i> pa.5 ;</p> <p>Result: set bit 5 of port A to high</p> <p>Affected flags: 『N』 Z 『N』 C 『N』 AC 『N』 OV</p>
<i>set0</i> M.n	<p>Set bit n of memory to low</p> <p>Example: <i>set0</i> MEM.5 ;</p> <p>Result: set bit 5 of MEM to low</p> <p>Affected flags: 『N』 Z 『N』 C 『N』 AC 『N』 OV</p>
<i>set1</i> M.n	<p>Set bit n of memory to high</p> <p>Example: <i>set1</i> MEM.5 ;</p> <p>Result: set bit 5 of MEM to high</p> <p>Affected flags: 『N』 Z 『N』 C 『N』 AC 『N』 OV</p>

<i>swapc</i> IO.n	<p>Swap the nth bit of IO port with carry bit</p> <p>Example: <code>swapc IO.0;</code></p> <p>Result: $C \leftarrow IO.0, IO.0 \leftarrow C$</p> <p>When IO.0 is a port to output pin, carry C will be sent to IO.0;</p> <p>When IO.0 is a port from input pin, IO.0 will be sent to carry C;</p> <p>Affected flags: 『N』 Z 『Y』 C 『N』 AC 『N』 OV</p> <p>Application Example1 (serial output) :</p> <pre> ... set1 pac.0 ; // set PA.0 as output ... set0 flag.1 ; // C=0 swapc pa.0 ; // move C to PA.0 (bit operation), PA.0=0 set1 flag.1 ; // C=1 swapc pa.0 ; // move C to PA.0 (bit operation), PA.0=1 ... </pre> <p>Application Example2 (serial input) :</p> <pre> ... set0 pac.0 ; // set PA.0 as input ... swapc pa.0 ; // read PA.0 to C (bit operation) src a ; // shift C to bit 7 of ACC swapc pa.0 ; // read PA.0 to C (bit operation) src a ; // shift new C to bit 7, old C ... </pre>
-------------------	---

7.6. Conditional Operation Instructions

<i>ceqsn</i> a, I	<p>Compare ACC with immediate data and skip next instruction if both are equal.</p> <p>Flag will be changed like as ($a \leftarrow a - I$)</p> <p>Example: <code>ceqsn a, 0x55 ;</code> <code>inc MEM ;</code> <code>goto error ;</code></p> <p>Result: If a=0x55, then “goto error”; otherwise, “inc MEM”.</p> <p>Affected flags: 『Y』 Z 『Y』 C 『Y』 AC 『Y』 OV</p>
<i>ceqsn</i> a, M	<p>Compare ACC with memory and skip next instruction if both are equal.</p> <p>Flag will be changed like as ($a \leftarrow a - M$)</p> <p>Example: <code>ceqsn a, MEM;</code></p> <p>Result: If a=MEM, skip next instruction</p> <p>Affected flags: 『Y』 Z 『Y』 C 『Y』 AC 『Y』 OV</p>

<i>cneqsn a, M</i>	<p>Compare ACC with memory and skip next instruction if both are not equal. Flag will be changed like as ($a \leftarrow a - M$) Example: <i>cneqsn a, MEM;</i> Result: If $a \neq \text{MEM}$, skip next instruction Affected flags: 『Y』 Z 『Y』 C 『Y』 AC 『Y』 OV</p>
<i>cneqsn a, I</i>	<p>Compare ACC with immediate data and skip next instruction if both are no equal. Flag will be changed like as ($a \leftarrow a - I$) Example: <i>cneqsn a, 0x55;</i> <i>inc MEM;</i> <i>goto error;</i> Result: If $a \neq 0x55$, then “goto error”; Otherwise, “inc MEM”. Affected flags: 『Y』 Z 『Y』 C 『Y』 AC 『Y』 OV</p>
<i>t0sn IO.n</i>	<p>Check IO bit and skip next instruction if it's low Example: <i>t0sn pa.5;</i> Result: If bit 5 of port A is low, skip next instruction Affected flags: 『N』 Z 『N』 C 『N』 AC 『N』 OV</p>
<i>t1sn IO.n</i>	<p>Check IO bit and skip next instruction if it's high Example: <i>t1sn pa.5;</i> Result: If bit 5 of port A is high, skip next instruction Affected flags: 『N』 Z 『N』 C 『N』 AC 『N』 OV</p>
<i>t0sn M.n</i>	<p>Check memory bit and skip next instruction if it's low Example: <i>t0sn MEM.5;</i> Result: If bit 5 of MEM is low, then skip next instruction Affected flags: 『N』 Z 『N』 C 『N』 AC 『N』 OV</p>
<i>t1sn M.n</i>	<p>Check memory bit and skip next instruction if it's high Example: <i>t1sn MEM.5;</i> Result: If bit 5 of MEM is high, then skip next instruction Affected flags: 『N』 Z 『N』 C 『N』 AC 『N』 OV</p>
<i>izsn a</i>	<p>Increment ACC and skip next instruction if ACC is zero Example: <i>izsn a;</i> Result: $a \leftarrow a + 1$, skip next instruction if $a = 0$ Affected flags: 『Y』 Z 『Y』 C 『Y』 AC 『Y』 OV</p>
<i>dzsn a</i>	<p>Decrement ACC and skip next instruction if ACC is zero Example: <i>dzsn a;</i> Result: $A \leftarrow A - 1$, skip next instruction if $a = 0$ Affected flags: 『Y』 Z 『Y』 C 『Y』 AC 『Y』 OV</p>
<i>izsn M</i>	<p>Increment memory and skip next instruction if memory is zero Example: <i>izsn MEM;</i> Result: $\text{MEM} \leftarrow \text{MEM} + 1$, skip next instruction if $\text{MEM} = 0$ Affected flags: 『Y』 Z 『Y』 C 『Y』 AC 『Y』 OV</p>
<i>dzsn M</i>	<p>Decrement memory and skip next instruction if memory is zero Example: <i>dzsn MEM;</i> Result: $\text{MEM} \leftarrow \text{MEM} - 1$, skip next instruction if $\text{MEM} = 0$ Affected flags: 『Y』 Z 『Y』 C 『Y』 AC 『Y』 OV</p>

7.7. System control Instructions

<i>call</i> label	<p>Function call, address can be full range address space</p> <p>Example: <i>call</i> function1;</p> <p>Result: [sp] ← pc + 1 pc ← function1 sp ← sp + 2</p> <p>Affected flags: 『N』 Z 『N』 C 『N』 AC 『N』 OV</p>
<i>goto</i> label	<p>Go to specific address which can be full range address space</p> <p>Example: <i>goto</i> error;</p> <p>Result: Go to error and execute program.</p> <p>Affected flags: 『N』 Z 『N』 C 『N』 AC 『N』 OV</p>
<i>ret</i> l	<p>Place immediate data to ACC, then return</p> <p>Example: <i>ret</i> 0x55;</p> <p>Result: A ← 55h ret ;</p> <p>Affected flags: 『N』 Z 『N』 C 『N』 AC 『N』 OV</p>
<i>ret</i>	<p>Return to program which had function call</p> <p>Example: <i>ret</i>;</p> <p>Result: sp ← sp - 2 pc ← [sp]</p> <p>Affected flags: 『N』 Z 『N』 C 『N』 AC 『N』 OV</p>
<i>reti</i>	<p>Return to program from interrupt service routine. After this command is executed, global interrupt is enabled automatically.</p> <p>Example: <i>reti</i>;</p> <p>Affected flags: 『N』 Z 『N』 C 『N』 AC 『N』 OV</p>
<i>nop</i>	<p>No operation</p> <p>Example: <i>nop</i>;</p> <p>Result: nothing changed</p> <p>Affected flags: 『N』 Z 『N』 C 『N』 AC 『N』 OV</p>
<i>pcadd</i> a	<p>Next program counter is current program counter plus ACC.</p> <p>Example: <i>pcadd</i> a;</p> <p>Result: pc ← pc + a</p> <p>Affected flags: 『N』 Z 『N』 C 『N』 AC 『N』 OV</p> <p>Application Example:</p> <pre> ----- ... mov a, 0x02 ; pcadd a ; // PC <- PC+2 goto err1 ; goto correct ; // jump here goto err2 ; goto err3 ; ... correct: // jump here ... ----- </pre>

<i>engint</i>	<p>Enable global interrupt enable Example: <i>engint</i>; Result: Interrupt request can be sent to FPP0 Affected flags: 『N』 Z 『N』 C 『N』 AC 『N』 OV</p>
<i>disgint</i>	<p>Disable global interrupt enable Example: <i>disgint</i> ; Result: Interrupt request is blocked from FPP0 Affected flags: 『N』 Z 『N』 C 『N』 AC 『N』 OV</p>
<i>stopsys</i>	<p>System halt. Example: <i>stopsys</i>; Result: Stop the system clocks and halt the system Affected flags: 『N』 Z 『N』 C 『N』 AC 『N』 OV</p>
<i>stopexe</i>	<p>CPU halt. The oscillator module is still active to output clock, however, system clock is disabled to save power. Example: <i>stopexe</i>; Result: Stop the system clocks and keep oscillator modules active. Affected flags: 『N』 Z 『N』 C 『N』 AC 『N』 OV</p>
<i>reset</i>	<p>Reset the whole chip, its operation will be same as hardware reset. Example: <i>reset</i>; Result: Reset the whole chip. Affected flags: 『N』 Z 『N』 C 『N』 AC 『N』 OV</p>
<i>wdreset</i>	<p>Reset Watchdog timer. Example: <i>wdreset</i> ; Result: Reset Watchdog timer. Affected flags: 『N』 Z 『N』 C 『N』 AC 『N』 OV</p>

7.8. Summary of Instructions Execution Cycle

2T		<i>goto, call, pcadd, ret, reti, idxm</i>
2T	Condition is fulfilled.	<i>ceqsn, cneqsn, t0sn, t1sn, dzsn, izsn</i>
1T	Condition is not fulfilled.	
1T		Others

7.9. Summary of affected flags by Instructions

Instruction	Z	C	AC	OV	Instruction	Z	C	AC	OV	Instruction	Z	C	AC	OV
<i>mov</i> a, l	-	-	-	-	<i>mov</i> M, a	-	-	-	-	<i>mov</i> a, M	Y	-	-	-
<i>mov</i> a, IO	Y	-	-	-	<i>mov</i> IO, a	-	-	-	-	<i>ldt16</i> word	-	-	-	-
<i>stt16</i> word	-	-	-	-	<i>idxm</i> a, index	-	-	-	-	<i>idxm</i> index, a	-	-	-	-
<i>xch</i> M	-	-	-	-	<i>pushaf</i>	-	-	-	-	<i>popaf</i>	Y	Y	Y	Y
<i>add</i> a, l	Y	Y	Y	Y	<i>add</i> a, M	Y	Y	Y	Y	<i>add</i> M, a	Y	Y	Y	Y
<i>addc</i> a, M	Y	Y	Y	Y	<i>addc</i> M, a	Y	Y	Y	Y	<i>addc</i> a	Y	Y	Y	Y
<i>addc</i> M	Y	Y	Y	Y	<i>sub</i> a, l	Y	Y	Y	Y	<i>sub</i> a, M	Y	Y	Y	Y
<i>sub</i> M, a	Y	Y	Y	Y	<i>subc</i> a, M	Y	Y	Y	Y	<i>subc</i> M, a	Y	Y	Y	Y
<i>subc</i> a	Y	Y	Y	Y	<i>subc</i> M	Y	Y	Y	Y	<i>inc</i> M	Y	Y	Y	Y
<i>dec</i> M	Y	Y	Y	Y	<i>clear</i> M	-	-	-	-	<i>sr</i> a	-	Y	-	-
<i>src</i> a	-	Y	-	-	<i>sr</i> M	-	Y	-	-	<i>src</i> M	-	Y	-	-
<i>sl</i> a	-	Y	-	-	<i>slc</i> a	-	Y	-	-	<i>sl</i> M	-	Y	-	-
<i>slc</i> M	-	Y	-	-	<i>swap</i> a	-	-	-	-	<i>and</i> a, l	Y	-	-	-
<i>and</i> a, M	Y	-	-	-	<i>and</i> M, a	Y	-	-	-	<i>or</i> a, l	Y	-	-	-
<i>or</i> a, M	Y	-	-	-	<i>or</i> M, a	Y	-	-	-	<i>xor</i> a, l	Y	-	-	-
<i>xor</i> IO, a	-	-	-	-	<i>xor</i> a, M	Y	-	-	-	<i>xor</i> M, a	Y	-	-	-
<i>not</i> a	Y	-	-	-	<i>not</i> M	Y	-	-	-	<i>neg</i> a	Y	-	-	-
<i>neg</i> M	Y	-	-	-	<i>set0</i> IO.n	-	-	-	-	<i>set1</i> IO.n	-	-	-	-
<i>set0</i> M.n	-	-	-	-	<i>set1</i> M.n	-	-	-	-	<i>ceqsn</i> a, l	Y	Y	Y	Y
<i>ceqsn</i> a, M	Y	Y	Y	Y	<i>t0sn</i> IO.n	-	-	-	-	<i>t1sn</i> IO.n	-	-	-	-
<i>t0sn</i> M.n	-	-	-	-	<i>t1sn</i> M.n	-	-	-	-	<i>izsn</i> a	Y	Y	Y	Y
<i>dzsn</i> a	Y	Y	Y	Y	<i>izsn</i> M	Y	Y	Y	Y	<i>dzsn</i> M	Y	Y	Y	Y
<i>call</i> label	-	-	-	-	<i>goto</i> label	-	-	-	-	<i>ret</i> l	-	-	-	-
<i>ret</i>	-	-	-	-	<i>reti</i>	-	-	-	-	<i>nop</i>	-	-	-	-
<i>pcadd</i> a	-	-	-	-	<i>engint</i>	-	-	-	-	<i>disgint</i>	-	-	-	-
<i>stopsys</i>	-	-	-	-	<i>stopexe</i>	-	-	-	-	<i>reset</i>	-	-	-	-
<i>wdreset</i>	-	-	-	-	<i>swapc</i> IO.n	-	Y	-	-	<i>cneqsn</i> a, l	Y	Y	Y	Y
<i>cneqsn</i> a, M	Y	Y	Y	Y	<i>nadd</i> M, a	Y	Y	Y	Y	<i>nadd</i> a, M	Y	Y	Y	Y
<i>comp</i> M, a	Y	Y	Y	Y	<i>comp</i> a, M	Y	Y	Y	Y	<i>index</i>	-	-	-	-

7.10. BIT definition

Bit access of RAM is only available for address from 0x00 to 0x3F.

8. Code Option Table

Option	Selection	Description
Security	Enable	OTP content is protected and program cannot be read back
	Disable	OTP content is not protected so program can be read back
EMI	Disable	Disable EMI optimize option
	Enable	The system clock will be slightly vibrated for better EMI performance
PA7_Sel	AS_CS	Configure pad PA7/CS as normal CS pad
	As_IO	Configure pad PA7/CS as normal PA7 IO pad
LVR	16 levels	4.5V, 4.0V, 3.75V, 3.5V, 3.3V, 3.15V, 3.0V, 2.7V, 2.5V, 2.4V, 2.3V, 2.2V, 2.1V, 2.0V, 1.9V, 1.8V
Interrupt_Src0	PA.0	Inten.0 / Intrq.0 used in interrupt PA.0
	PA.5	Inten.0 / Intrq.0 used in interrupt PA.5 (ICE doesn't support.)

9. Special Notes

This chapter is to remind user who use PMS161 IC in order to avoid frequent errors upon operation.

9.1. Using IC

9.1.1. IO pin usage and setting

- (1) IO pin is set to be digital input
 - ◆ When IO is as digital input, the level of Vih and Vil would changes with the voltage and temperature. Please follow the minimum value of Vih and the maximum value of Vil.
 - ◆ The value of internal pull high resistor would also change with the voltage, temperature and pin voltage. It is not the fixed value.
- (2) IO pin is set to be digital input and enable wakeup function
 - ◆ Configure IO pin as input
 - ◆ Set PADIER registers to set the corresponding bit to 1.
- (3) PA5 is set to be PRSTB input pin
 - ◆ Configure PA5 as input
 - ◆ Set CLKMD.0=1 to enable PA5 as PRSTB input pin
- (4) PA5 is set to be input pin and to connect with a push button or a switch by a long wire
 - ◆ Needs to put a >33Ω resistor in between PA5 and the long wire
 - ◆ Avoid using PA5 as input in such application.

9.1.2. Interrupt

(1) When using the interrupt function, the procedure should be:

Step1: Set INTEN register, enable the interrupt control bit.

Step2: Clear INTRQ register.

Step3: In the main program, using ENGINT to enable CPU interrupt function.

Step4: Wait for interrupt. When interrupt occurs, enter to Interrupt Service Routine.

Step5: After the Interrupt Service Routine being executed, return to the main program.

*Use DISGINT in the main program to disable all interrupts.

*When interrupt service routine starts, use PUSHAF instruction to save ALU and FLAG register.

POPAF instruction is to restore ALU and FLAG register before RETI as below:

```
void Interrupt (void) // Once the interrupt occurs, jump to interrupt service routine
{
    // enter DISGINT status automatically, no more interrupt is accepted
    PUSHAF;
    ...
    POPAF;
} // RETI will be added automatically. After RETI being executed, ENGINT status will be restored
```

(2) INTEN and INTRQ have no initial values. Please set required value before enabling interrupt function.

9.1.3. System clock switching

System clock can be switched by CLKMD register. Please notice that, NEVER switch the system clock and turn off the original clock source at the same time. For example: When switching from clock A to clock B, please switch to clock B first; and after that turn off the clock A oscillator through CLKMD.

- ◆ Switch system clock from ILRC to IHRC/2
 - CLKMD = 0x36; // switch to IHRC, *ILRC can not be disabled here*
 - CLKMD.2 = 0; // ILRC can be disabled at this time
- ◆ **ERROR.** Switch ILRC to IHRC and turn off ILRC simultaneously
 - CLKMD = 0x50; // MCU will hang

9.1.4. Power down mode, wakeup and watchdog

Watchdog is open by default, but when the program executes ADJUST_IC, the watchdog will be closed. To use the watchdog, you need to reconfigure the open. Watchdog will be inactive once ILRC is disabled.

9.1.5. TIMER time out

When select \$ INTEGS BIT_R (default value) and T16M counter BIT8 to generate interrupt, if T16M counts from 0, the first interrupt will occur when the counter reaches to 0x100 (BIT8 from 0 to 1) and the second interrupt will occur when the counter reaches 0x300 (BIT8 from 0 to 1). Therefore, selecting BIT8 as 1 to generate interrupt means that the interrupt occurs every 512 counts. Please notice that if T16M counter is restarted, the next interrupt will occur once Bit8 turns from 0 to 1.

If select \$ INTEGS BIT_F (BIT triggers from 1 to 0) and T16M counter BIT8 to generate interrupt, the T16M counter changes to an interrupt every 0x200/0x400/0x600/. Please pay attention to two differences with setting INTEGS methods.

9.1.6. IHRC

- (1) The IHRC frequency calibration is performed when IC is programmed by the writer.
- (2) Because the characteristic of the Epoxy Molding Compound (EMC) would some degrees affects the IHRC frequency (either for package or COB), if the calibration is done before molding process, the actual IHRC frequency after molding may be deviated or becomes out of spec. Normally, the frequency is getting slower a bit.
- (3) It usually happens in COB package or Quick Turnover Programming (QTP). And PADAUK would not take any responsibility for this situation.
- (4) Users can make some compensatory adjustments according to their own experiences. For example, users can set IHRC frequency to be 0.5% ~ 1% higher and aim to get better re-targeting after molding.

9.1.7. LVR

LVR level selection is done at compile time. User must select LVR based on the system working frequency and power supply voltage to make the MCU work stably.

The following are Suggestions for setting operating frequency, power supply voltage and LVR level:

SYSCLK	VDD	LVR
2MHz	≥ 2.2V	≥ 2.2V
4MHz	≥ 2.5V	≥ 2.5V
8MHz	≥ 3.5V	≥ 3.5V

Table 8: LVR setting for reference

- (1) The setting of LVR (1.8V ~ 4.5V) will be valid just after successful power-on process.
- (2) User can set MISC.2 as “1” to disable LVR. However, V_{DD} must be kept as exceeding the lowest working voltage of chip; Otherwise IC may work abnormally.
- (3) The LVR function will be invalid when IC in stopexe or stopsys mode.

9.1.8. Programming Writing

There are 6 signals for programming PMS161: PA3, PA4, PA5, PA6, V_{DD}, and GND.

Please follow the instruction displayed at the software to connect the jumper.

- Special notes about voltage and current while Multi-Chip-Package(MCP) or On-Board Programming
 - (1) PA5 (V_{PP}) may be higher than 6.5V.
 - (2) V_{DD} may be higher than 9.5V, and its maximum current may reach about 20mA.
 - (3) All other signal pins level (except GND) are the same as V_{DD}.

User should confirm when using this product in MCP or On-Board Programming, the peripheral circuit or components will not be destroyed or limit the above voltages.

9.1.8.1. Using 5S-P-003 to write PMS161

5S-P-003 writing all packages of PMS161 need special convert. Taking the writing of PMS161-S08B as an example, other packages only need to change the chip package in the “package setting” interface and jumper7 connection.

1. Convert the PDK file

Enter the writing interface from the IDE, then click “Convert” -> “To Package”. In the “Package Setting” interface, select the package with the suffix [P003] (as shown in Figure.20), then click “Only Program PIN” and “VDD/PA5 Swap on JP7 adapter”. After confirming information about the IC pin, save and use the newly generated PDK file. Please refer to Figure 19 and Figure 20 for specific operation steps.

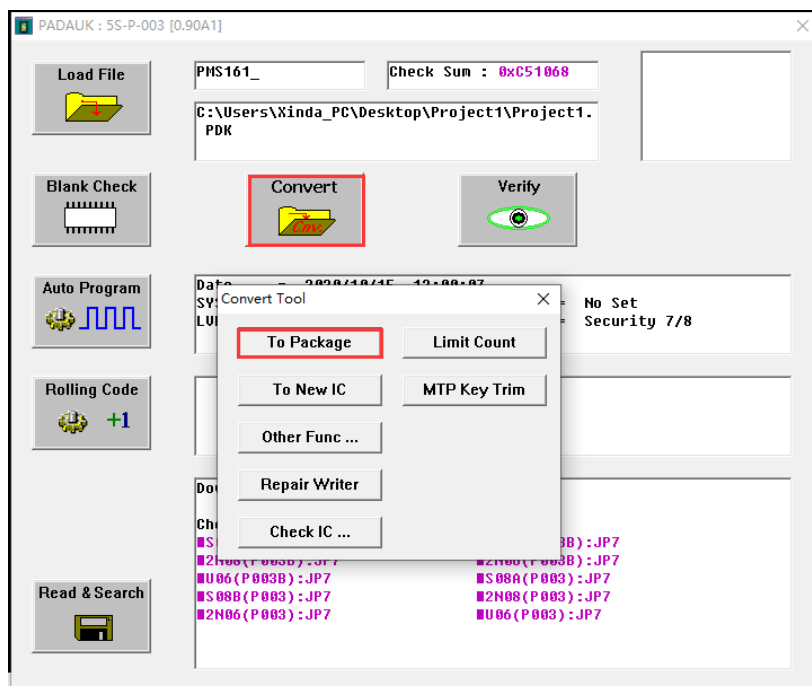

Fig.19: convert the PDK file

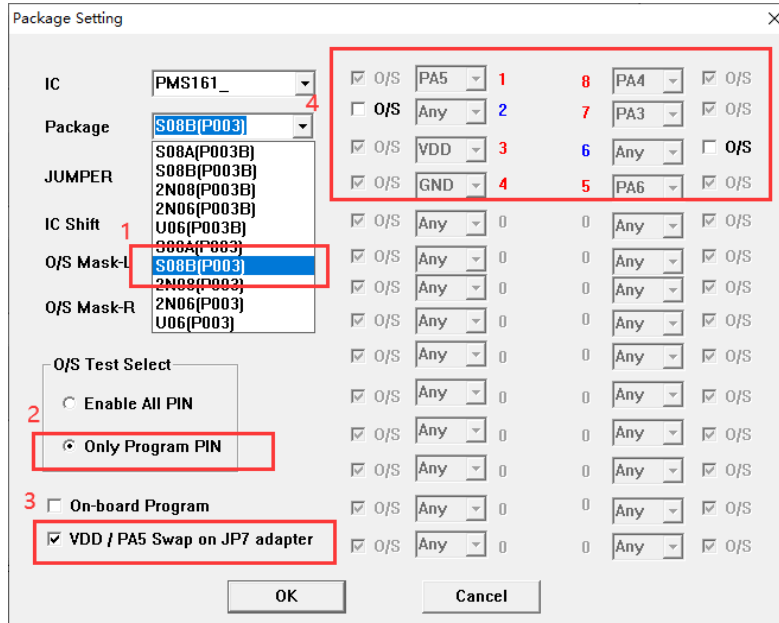

Fig.20: PMS161-S08B package setting when using P003

2. As shown in figure 21, it is the Jumper7 connection method.

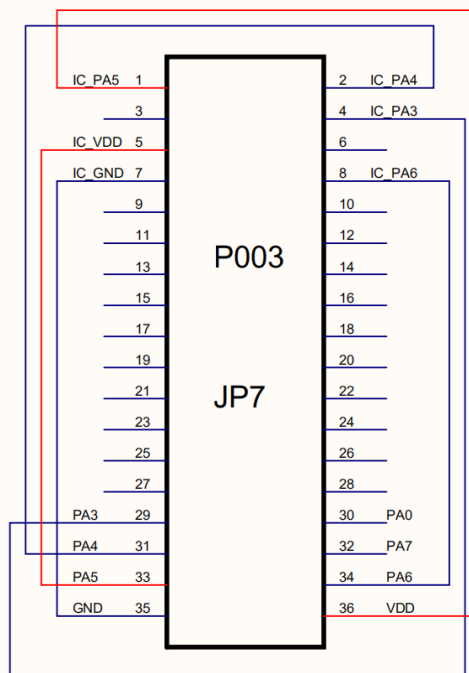

Fig.21: schematic diagram of PMS161-S08B Jumper7 when using p003

Note: VDD / PA5 needs to swap with each other when using jumper7. For example, writer VDD-PIN connect to IC-PA5 and Writer PA5-PIN connect to IC-VDD.

3. Insert JP7 adaptor board and input IC on the socket without shift. After LCDM displays IC ready, it can be written.

9.1.8.2. Using 5S-P-003B to write PMS161

1. For 5S-P-003B to write PMS161-S08A, just use jumper2 and it needs downward four spaces on the Textool. Other packages need to convert the file and use jumper7. Taking the writing of PMS161-S08B as an example, other packages only need to change the chip package and jumper7 connection in the “package setting” interface. The package settings are shown in Figure 22:

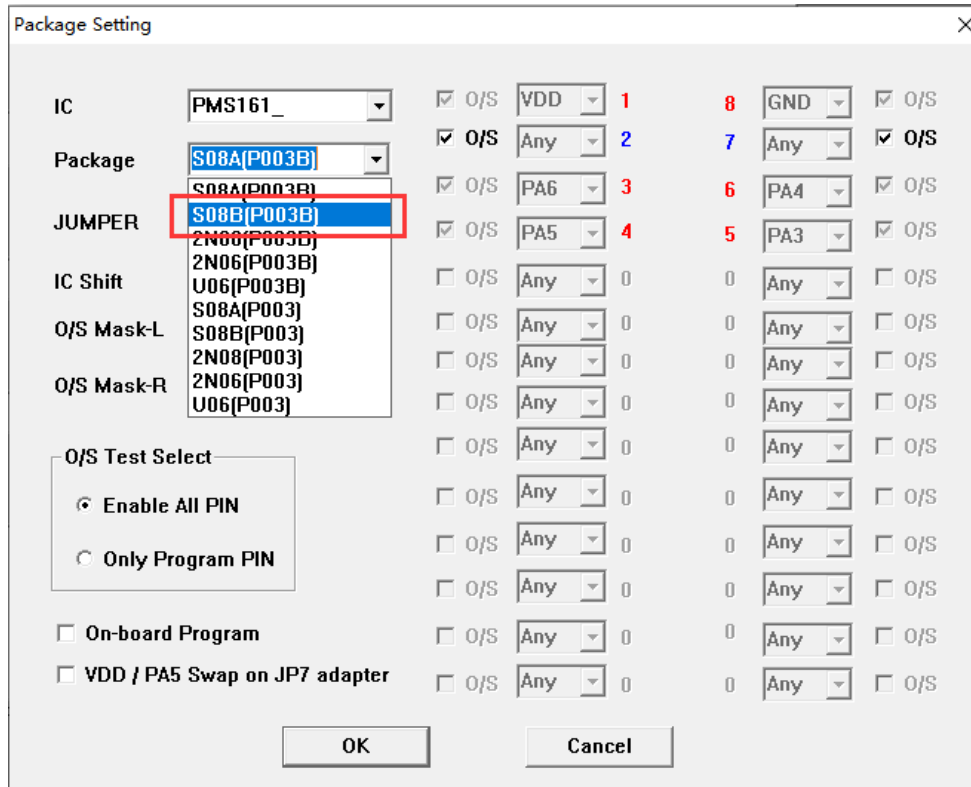

Fig.22: PMS161-S08B package setting when using P003B

2. As shown in figure 23, it is the Jumper7 connection method.

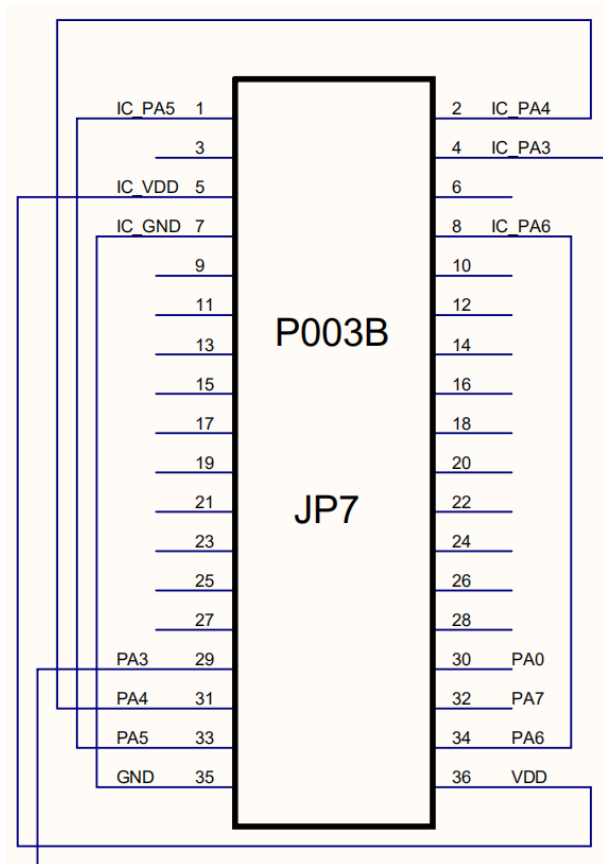

Fig.23: schematic diagram of PMS161-S08B Jumper7 when using P003B

Note: VDD/PA5 DOES NOT need to swap with each other when using 5S-P003B Jumper7.

3. Insert JP7 and input IC on the socket without shift. After LCDM displays IC ready, it can be written.

9.2. Using ICE

(1) The following items should be noted when using 5S-I-S01/2(B) to emulate PMS161:

- 5S-I-S01/2(B) doesn't support SYSCLK=ILRC/16 and ILRC/64.
- 5S-I-S01/2(B) doesn't support Tm3c.NILRC wake-up function.
- 5S-I-S01/2(B) doesn't support PA5 as the interrupt source.
- 5S-I-S01/2(B) doesn't support the code options: GPC_PWM, TMx_source, TMx_bit.
- 5S-I-S01/2(B) doesn't support ALL touch function.
- The PA3 output function will be affected when GPCS selects output to PA0 output.
- 5S-I-S01/2(B) doesn't support Timer2/Timer3 function with comparator as clock source, but 6S-M-001 can emulate.
- When simulating PWM waveform, please check the waveform during program running. When the ICE is suspended or single-step running, its waveform may be inconsistent with the reality.
- The ILRC frequency of the 5S-I-S01/2(B) simulator is different from the actual IC and is uncalibrated, with a frequency range of about 34K~38KHz.
- Fast Wakeup time is different from 5S-I-S01/2(B): 128 SysClk, PMS161: 45 ILRC.
- Watch dog time out period is different from 5S-I-S01/2(B).

WDT period	5S-I-S01/2(B)	PMS161
misc[1:0]=00	2048 * T _{ILRC}	8192 * T _{ILRC}
misc[1:0]=01	4096 * T _{ILRC}	16384 * T _{ILRC}
misc[1:0]=10	16384 * T _{ILRC}	65536 * T _{ILRC}
misc[1:0]=11	256 * T _{ILRC}	262144 * T _{ILRC}